

SERVICE MANUAL

NAD

S170i
AV SURROUND
SOUND
PREAMPLIFIER

S170i

AV SURROUND
SOUND
PREAMPLIFIER

PRODUCT SAFETY SERVICING GUIDELINES

CAUTION : DO NOT ATTEMPT TO MODIFY THIS PRODUCT IN ANY WAY. NEVER PERFORM CUSTOMIZED INSTALLATIONS WITHOUT MANUFACTURER'S APPROVAL. UNAUTHORIZED MODIFICATIONS WILL NOT ONLY VOID THE WARRANTY, BUT MAY LEAD TO YOUR BEING LIABLE FOR ANY RESULTING PROPERTY DAMAGE OR USER INJURY.

SERVICE WORK SHOULD BE PERFORMED ONLY AFTER YOU ARE THOROUGHLY FAMILIAR WITH ALL OF THE FOLLOWING SAFETY CHECKS AND SERVICING GUIDELINES. TO DO OTHERWISE, INCREASES THE RISK OF POTENTIAL HAZARDS AND INJURY TO THE USER.

WHILE SERVICING, USE AN ISOLATION TRANSFORMER FOR PROTECTION FROM AC LINE SHOCK.

SAFETY CHECKS

AFTER THE ORIGINAL SERVICE PROBLEM HAS BEEN CORRECTED. A CHECK SHOULD BE MADE OF THE FOLLOWING.

SUBJECT : FIRE & SHOCK HAZARD

1. BE SURE THAT ALL COMPONENTS ARE POSITIONED IN SUCH A WAY AS TO AVOID POSSIBILITY OF ADJACENT COMPONENT SHORTS. THIS IS ESPECIALLY IMPORTANT ON THOSE MODULES WHICH ARE TRANSPORTED TO AND FROM THE REPAIR SHOP.
2. NEVER RELEASE A REPAIR UNLESS ALL PROTECTIVE DEVICES SUCH AS INSULATORS, BARRIERS, COVERS, SHIELDS, STRAIN RELIEFS, POWER SUPPLY CORDS, AND OTHER HARDWARE HAVE BEEN REINSTALLED PER ORIGINAL DESIGN. BE SURE THAT THE SAFETY PURPOSE OF THE POLARIZED LINE PLUG HAS NOT BEEN DEFEATED.
3. SOLDERING MUST BE INSPECTED TO DISCOVER POSSIBLE COLD SOLDER JOINTS, SOLDER SPLASHES OR SHARP SOLDER POINTS. BE CERTAIN TO REMOVE ALL LOOSE FOREIGN PARTICLES.
4. CHECK FOR PHYSICAL EVIDENCE OF DAMAGE OR DETERIORATION TO PARTS AND COMPONENTS. FOR FRAYED LEADS, DAMAGED INSULATION (INCLUDING AC CORD). AND REPLACE IF NECESSARY FOLLOW ORIGINAL LAYOUT, LEAD LENGTH AND DRESS.
5. NO LEAD OR COMPONENT SHOULD TOUCH A RECEIVING TUBE OR A RESISTOR RATED AT 1 WATT OR MORE. LEAD TENSION AROUND PROTRUDING METAL SURFACES MUST BE AVOIDED.
6. ALL CRITICAL COMPONENTS SUCH AS FUSES, FLAMEPROOF RESISTORS, CAPACITORS, ETC. MUST BE REPLACED WITH EXACT FACTORY TYPES, DO NOT USE REPLACEMENT COMPONENTS OTHER THAN THOSE SPECIFIED OR MAKE UNRECOMMENDED CIRCUIT MODIFICATIONS.
7. AFTER RE-ASSEMBLY OF THE SET ALWAYS PERFORM AN AC LEAKAGE TEST ON ALL EXPOSED METALLIC PARTS OF THE CABINET, (THE CHANNEL SELECTOR KNOB, ANTENNA TERMINALS. HANDLE AND SCREWS) TO BE SURE THE SET IS SAFET TO OPERATE WITHOUT DANGER OF ELECTRICAL SHOCK. DO NOT USE A LINE ISOLATION TRANSFORMER DURING THIS TEST USE AN AC VOLTMETER, HAVING 5000 OHMS PER VOLT OR MORE SENSITIVITY, IN THE FOLLOWING MANNER; CONNECT A 1500 OHM 10 WATT RESISTOR, PARALLELED BY A .15 MFD, 150V AC TYPE CAPACITOR BETWEEN A KNOWN GOOD EARTH GROUND (WATER PIPE, CONDUIT, ETC.) AND THE EXPOSED METALLIC PARTS, ONE AT A TIME.
MEASURE THE AC VOLTAGE ACROSS THE COMBINATION OF 1500 OHM RESISTOR AND .15 MFD CAPACITOR.
REVERSE THE AC PLUG AND REPEAT AC VOLTAGE MEASUREMENTS FOR EACH EXPOSED METALLIC PART.

VOLTAGE MEASURE MUST NOT EXCEED 75 VOLTS R.M.S. THIS CORRESPONDS TO 0.5 MILLIAMPER AC ANY VALUE EXCEEDING THIS LIMIT CONSTITUTES A POTENTIAL SHOCK HAZARD AND MUST BE CORRECTED IMMEDIATELY.

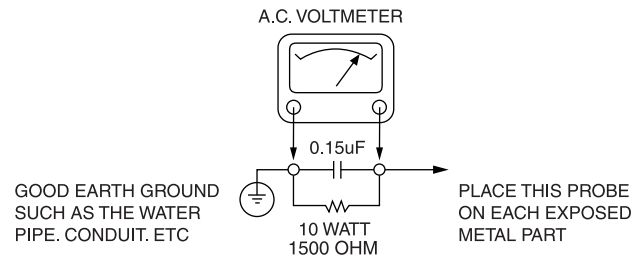

SUBJECT : GRAPHIC SYMBOLS



THE LIGHTNING FLASH WITH ARROWHEAD SYMBOL, WITHIN AN EQUILATERAL TRIANGLE, IS INTENDED TO ALERT THE USER TO THE PRESENCE OF UNINSULATED "DANGEROUS VOLTAGE" WITHIN THE PRODUCT'S ENCLOSURE THAT MAY BE OF SUFFICIENT MAGNITUDE TO CONSTITUTE A RISK OF ELECTRIC SHOCK.



THE EXCLAMATION POINT WITHIN AN EQUILATERAL TRIANGLE IS INTENDED TO ALERT THE USER TO THE PRESENCE OF IMPORTANT OPERATING AND MAINTENANCE (SERVICING) INSTRUCTIONS IN THE LITERATURE ACCOMPANYING THE APPLIANCE.

SUBJECT : TIPS ON PROPER INSTALLATION

1. NEVER INSTALL ANY PRODUCT IN A CLOSED-IN RECESS, CUBBYHOLE OR CLOSELY FITTING SHELF SPACE. OVER OR CLOSE TO HEAT DUCT, OR IN THE PATH OF HEATED AIR FLOW.
2. AVOID CONDITIONS OF HIGH HUMIDITY SUCH AS: OUTDOOR PATIO INSTALLATIONS WHERE DEW IS A FACTOR, NEAR STEAM RADIATORS WHERE STEAM LEAKAGE IS A FACTOR, ETC.
3. AVOID PLACEMENT WHERE DRAPERIES MAY OBSTRUCT REAR VENTING. THE CUSTOMER SHOULD ALSO AVOID THE USE OF DECORATIVE SCARVES OR OTHER COVERINGS WHICH MIGHT OBSTRUCT VENTILATION.
4. WALL AND SHELF MOUNTED INSTALLATIONS USING A COMMERCIAL MOUNTING KIT MUST FOLLOW THE FACTORY APPROVED MOUNTING INSTRUCTIONS A PRODUCT MOUNTED TO A SHELF OR PLATFORM MUST RETAIN ITS ORIGINAL FEET (OR THE EQUIVALENT THICKNESS IN SPACERS) TO PROVIDE ADEQUATE AIR FLOW ACROSS THE BOTTOM, BOLTS OR SCREWS USED FOR FASTENERS MUST NOT TOUCH ANY PARTS OR WIRING. PERFORM LEAKAGE TEST ON CUSTOMIZED INSTALLATIONS.
5. CAUTION CUSTOMERS AGAINST THE MOUNTING OF A PRODUCT ON SLOPING SHELF OR A TILTED POSITION, UNLESS THE PRODUCT IS PROPERLY SECURED.
6. A PRODUCT ON A ROLL-ABOUT CART SHOULD BE STABLE ON ITS MOUNTING TO THE CART. CAUTION THE CUSTOMER ON THE HAZARDS OF TRYING TO ROLL A CART WITH SMALL CASTERS ACROSS THRESHOLDS OR DEEP PILE CARPETS.
7. CAUTION CUSTOMERS AGAINST THE USE OF A CART OR STAND WHICH HAS NOT BEEN LISTED BY UNDERWRITERS LABORATORIES, INC. FOR USE WITH THEIR SPECIFIC MODEL OF TELEVISION RECEIVER OR GENERICALLY APPROVED FOR USE WITH T.V.'S OF THE SAME OR LARGER SCREEN SIZE.
8. CAUTION CUSTOMERS AGAINST THE USE OF EXTENSION CORDS, EXPLAIN THAT A FOREST OF EXTENSIONS SPROUTING FROM A SINGLE OUTLET CAN LEAD TO DISASTROUS CONSEQUENCES TO HOME AND FAMILY.

SERVICING PRECAUTIONS

CAUTION : Before servicing the A/V Receiver covered by this service data and its supplements and addends, read and follow the **SAFETY PRECAUTIONS**. **NOTE** : if unforeseen circumstances create conflict between the following servicing precautions and any of the safety precautions in this publication, always follow the safety precautions.

Remember Safety First:

General Servicing Precautions

1. Always unplug the A/V Receiver AC power cord from the AC power source before:
 - (1) Removing or reinstalling any component, circuit board, module, or any other assembly.
 - (2) Disconnecting or reconnecting any internal electrical plug or other electrical connection.
 - (3) Connecting a test substitute in parallel with an electrolytic capacitor.

Caution : A wrong part substitution or incorrect polarity installation of electrolytic capacitors may result in an explosion hazard.
2. Do not spray chemicals on or near this A/V Receiver or any of its assemblies.
3. Unless specified otherwise in this service data, clean electrical contacts by applying an appropriate contact cleaning solution to the contacts with a pipe cleaner, cottontipped swab, or comparable soft applicator.
Unless specified otherwise in this service data, lubrication of contacts is not required.
4. Do not defeat any plug/socket B+ voltage interlocks with which instruments covered by this service manual might be equipped.
5. Do not apply AC power to this A/V Receiver and/or any of its electrical assemblies unless all solid-state device heat sinks are correctly installed.
6. Always connect test instrument ground lead to the appropriate ground before connecting the test instrument positive lead. Always remove the test instrument ground lead last.

Insulation Checking Procedure

Disconnect the attachment plug from the AC outlet and turn the power on. Connect an insulation resistance meter(500V) to the blades of the attachment plug. The insulation resistance between each blade of the attachment plug and accessible conductive parts (Note 1) should be more than 1M-ohm.

Note 1 : Accessible Conductive Parts including Metal panels, Input terminals, Earphone jacks, etc.

Electrostatically Sensitive (ES) Devices

Some semiconductor (solid state) devices can be damaged easily by static electricity. Such components commonly are called Electrostatically Sensitive (ES) Devices. Examples of typical Es devices are integrated circuits and some field effect transistors and semiconductor chip components.

The following techniques should be used to help reduce the incidence of component damage caused by static electricity.

1. Immediately before handling any semiconductor component or semiconductor-equipped assembly, drain off any electrostatic charge on your body by touching a known earth ground. Alternatively, obtain and wear a commercially available discharging wrist strap device, which should be removed for potential shock reasons prior to applying power to the unit under test.
2. After removing an electrical assembly equipped with ES devices, place the assembly on a conductive surface such as aluminum foil, to prevent electrostatic charge buildup or exposure of the assembly.
3. Use only a grounded-tip soldering iron to solder or unsolder ES devices.
4. Use only an antistatic solder removal device. Some solder removal devices not classified a "anti-static" can generate electrical charges sufficient to damage ES devices.
5. Do not use freonpropelled chemicals. These can generate electrical charge sufficient to damage ES devices.
6. Do not remove a replacement ES device from its protective package until immediately before you are ready to install it. (Most replacement ES devices are packaged with leads electrically shorted together by conductive foam, aluminum foil, or comparable conductive material).
7. Immediately before removing the protective material from the leads of a replacement ES device, touch the protective material to the chassis or circuit assembly into which the device will be installed.

Caution : Be sure no power is applied to the chassis or circuit, and observe all other safety precautions.

8. Minimize bodily motions when handing unpackaged replacement ES devices. (Normally harmless motion such as the brushing together of your clothes fabric or the lifting of your foot from a carpeted floor can generate static electricity sufficient to damage an ES device.)



CONTENTS

| | |
|---|-------|
| FRONT PANEL / REAR PANEL VIEW | 3 |
| WIRING DIAGRAM | 4 |
| SPECIFICATIONS | 5 |
| BLOCK DIAGRAM | 6 |
| PCB LAYOUT | 7-10 |
| SCHEMATIC DIAGRAM | 11-25 |
| ELECTRICAL PARTS LIST | 26-35 |
| EXPLODED VIEW | 36 |
| EXPLODED VIEW PARTS LIST | xx |
| PACKING DIAGRAM | 38 |
| NOTES | 39 |

SERVICE SAFETY PRECAUTIONS

1. Replacing the Fuses

CAUTION: FOR CONTINUED PROTECTION AGAINST THE RISK OF FIRE REPLACE ONLY WITH SAME TYPE OF FUSE.

| REFERENCE NO. | PART NUMBER | DESCRIPTION |
|---|--------------|--------------------|
| FUSE1*C  | 5120-0050-0 | 1.6A 250V Time Lag |
| FUSE2*C  | 5100-1020-1B | 1A 250V Time Lag |
| FUSE3*C  | 5120-0065-0 | 2A 250V Time Lag |

NOTE:

*C : European version only

2. Safety-check out

Before returning the product to the customer, make leakage current or resistance measurements to determine that exposed parts are acceptably insulated from the supply circuit.

Parts marked with the symbol  are critical with regard to the risk of fire and electric shock. Replace only with parts recommended by the manufacturer.

FRONT PANEL CONTROLS

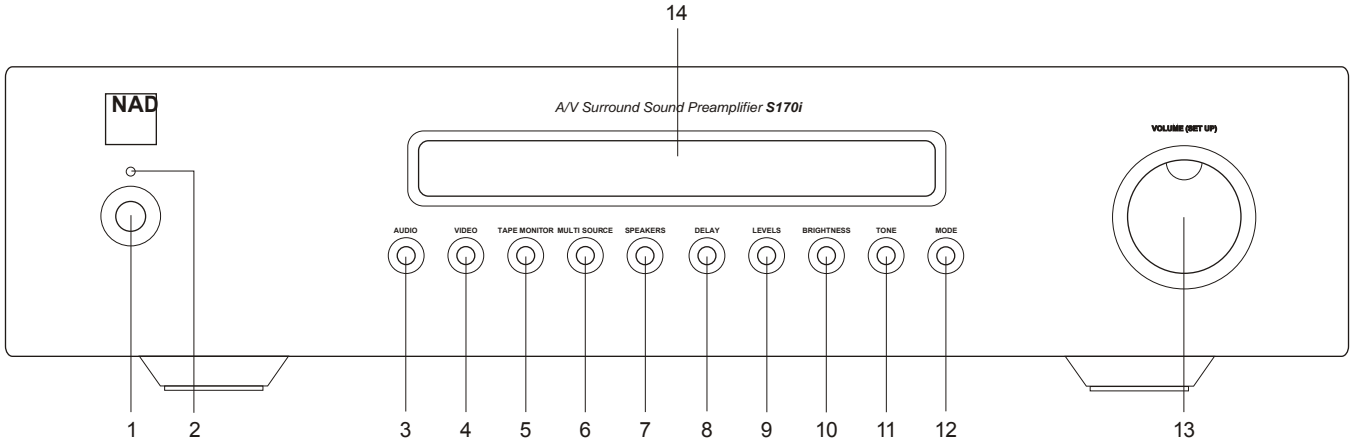

- | | | |
|-------------------------|-----------------|--------------------------|
| 1. POWER SWITCH | 6. MULTI SOURCE | 11. TONE |
| 2. POWER INDICATOR | 7. SPEAKERS | 12. MODE |
| 3. AUDIO INPUT SELECTOR | 8. DELAY | 13. VOLUME/SETUP CONTROL |
| 4. VIDEO INPUT SELECTOR | 9. LEVELS | 14. DISPLAY |
| 5. TAPE MONITOR | 10. BRIGHTNESS | |

The graphic symbol of a lightning flash with an arrow point within a triangle signifies that there is dangerous voltage within the unit and it poses a hazard to anyone removing the cover to gain access to the interior of the unit. **Only qualified service personnel should make such attempt.**

The graphic symbol of an exclamation point within an equilateral triangle warns a user of the device that it is necessary to refer to the instruction manual and its warnings for proper operation of the unit.

REAR PANEL CONNECTIONS

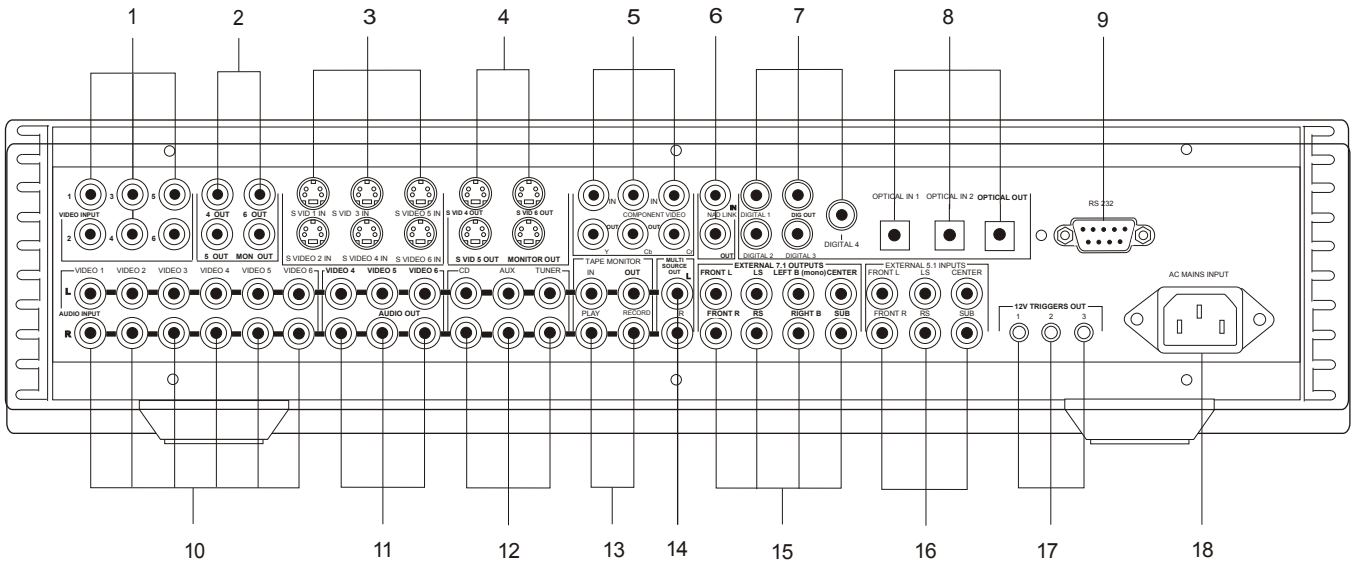

- | | | |
|-----------------------------------|----------------------------------|-------------------------|
| 1. VIDEO INPUTS | 7. COAXIAL DIGITAL INPUTS/OUTPUT | 13. TAPE INPUT/OUTPUT |
| 2. VIDEO OUTPUTS | 8. OPTICAL DIGITAL INPUTS/OUTPUT | 14. MULTI SOURCE OUTPUT |
| 3. S-VIDEO INPUTS | 9. RS-232 | 15. EXT. 7.1 OUTPUTS |
| 4. S-VIDEO OUTPUTS | 10. AUDIO INPUTS | 16. EXT. 5.1 INPUTS |
| 5. COMPONENT VIDEO INPUTS/OUTPUTS | 11. AUDIO OUTPUTS | 17. 12V TRIGGER OUTPUTS |
| 6. NAD LINK INPUT/OUTPUT | 12. CD/AUX/TUNER INPUTS | 18. AC INLET |

WIRING DIAGRAM

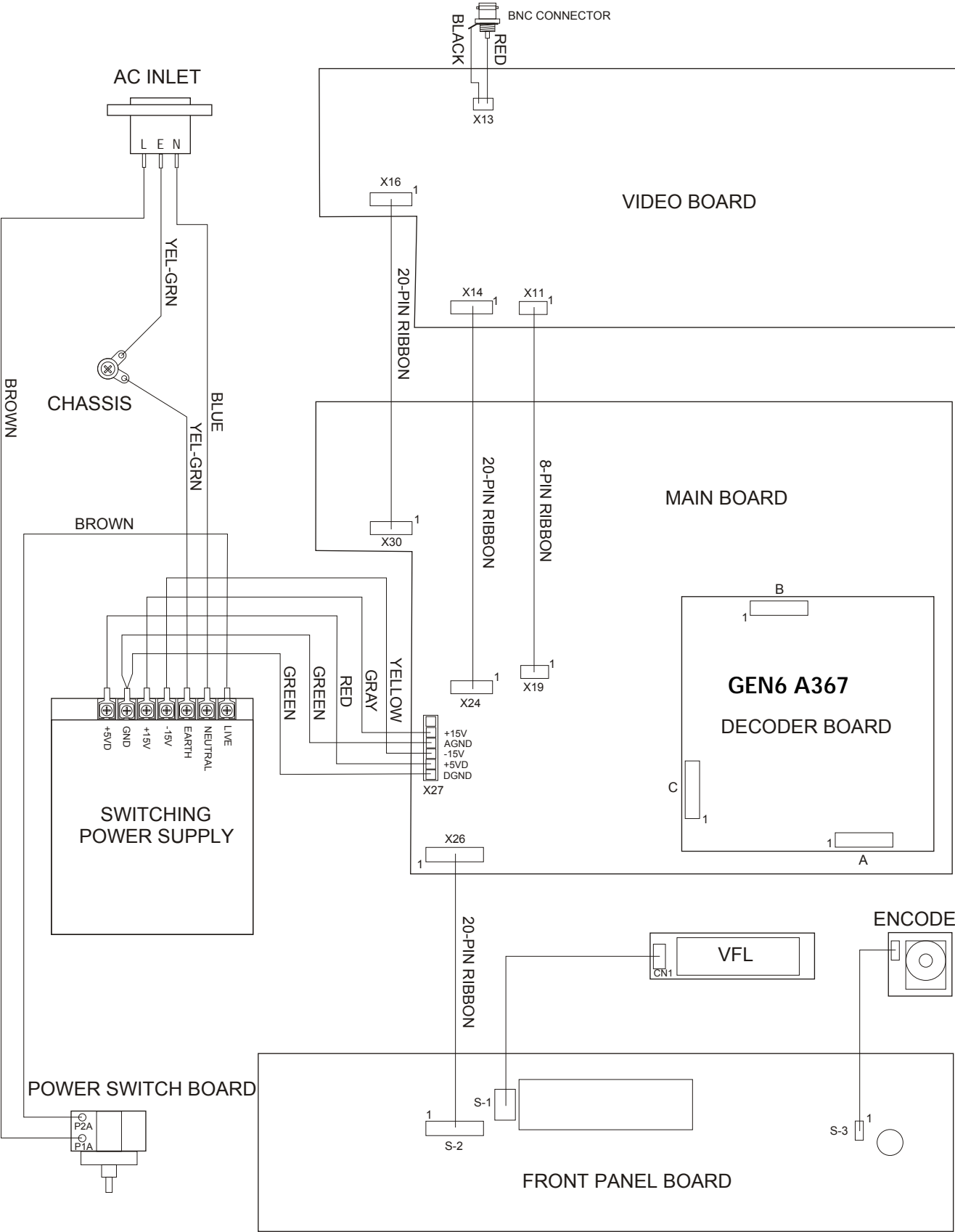

SPECIFICATIONS

STANDARD SETTINGS

1. Volume = 0dB
2. Tone Controls = 0dB
3. LFE Channel = 0dB
4. Bass Limiter = Off
5. Channel Levels = 0dB
6. Delays = 0 meters/ft
7. Speakers = Large
8. Subwoofer = Yes

SURROUND BACK LEFT & RIGHT

1. Dolby 1.0 test disc (5.1 input)
2. Choose titles with SL and SR signals
3. Put unit to 6.1 mode setting

DOLBY DIGITAL MODE: Dolby test disc 1.0

| | | | | |
|---|-------|-------------|-------------|---------------|
| 1. Output level | All 7 | Title 30 | 997Hz | 0.22 ± 0.03 V |
| 2. Channel Difference | All 5 | Title 30 | 997Hz | 0 ± 0.5 dB |
| 3. Frequency Response Title 30 for reference. For Sub, reference is start of title 48 | L | Title 43 | 200Hz-20kHz | 0 ± 0.2 dB |
| | R | Title 45 | 200Hz-20kHz | 0 ± 0.2 dB |
| | C | Title 44 | 200Hz-20kHz | 0 ± 0.2 dB |
| | SL | Title 46 | 200Hz-20kHz | 0 ± 0.2 dB |
| | SR | Title 47 | 200Hz-20kHz | 0 ± 0.2 dB |
| | Sub | Title 48 | 20Hz-80Hz | 0 ± 0.2 dB |
| 4. THD With audio BPF | L | Title 65 | 997Hz | ≤0.01% |
| | R | Title 67 | 997Hz | ≤0.01% |
| | C | Title 66 | 997Hz | ≤0.01% |
| | SL | Title 68 | 997Hz | ≤0.01% |
| | SR | Title 69 | 997Hz | ≤0.01% |
| | Sub | Title 70 | 30Hz | ≤0.03% |
| 5. S/N Ratio, A-wtd 20kHz LPF | All 5 | Title 63 | | ≥65dB |
| 6. Channel Separation 20kHz LPF | All 5 | Title 65-69 | 997Hz | ≥65dB |

DTS MODE: DTS Consumer Product Evaluation Test Disc

| | | | | |
|--|-------|----------|------------|---------------|
| 1. Output level For Sub, ref. L out at track 10 | All 5 | Track 21 | 1kHz | 0.22 ± 0.03 V |
| | Sub | Track 15 | 30Hz | +9.4 ± 1 dB |
| 2. Channel Difference | All 5 | Track 21 | 1kHz | 0 ± 0.5 dB |
| 3. Frequency Response Track 21 for reference | L | Track 26 | 20Hz-20kHz | 0 ± 0.2 dB |
| | R | Track 27 | 20Hz-20kHz | 0 ± 0.2 dB |
| | C | Track 30 | 20Hz-20kHz | 0 ± 0.5 dB |
| | SL | Track 28 | 20Hz-20kHz | 0 ± 0.5 dB |
| | SR | Track 29 | 20Hz-20kHz | 0 ± 0.5 dB |
| 4. THD | L | Track 10 | 1kHz | ≤0.01% |

| | | | | |
|----------------|----|----------|------|--------|
| With audio BPF | R | Track 11 | 1kHz | ≤0.01% |
| | C | Track 14 | 1kHz | ≤0.01% |
| | SL | Track 12 | 1kHz | ≤0.01% |
| | SR | Track 13 | 1kHz | ≤0.01% |

DOLBY PROLOGIC MODE: Analog input signal = 2V

| | | | | |
|--------------------------|----|--------|------|--------|
| 1. THD With 80kHz LPF | L | L | 1kHz | ≤0.05% |
| | R | R | 1kHz | ≤0.05% |
| | C | L = R | 1kHz | ≤0.05% |
| | SL | L = -R | 1kHz | ≤0.05% |
| | SR | L = -R | 1kHz | ≤0.05% |

| | | | | |
|---------------------|------|--------|------|-------|
| 2. S/N Ratio wtd | A- L | L | 1kHz | ≥85dB |
| | R | R | 1kHz | ≥85dB |
| | C | L = R | 1kHz | ≥85dB |
| | SL | L = -R | 1kHz | ≥85dB |
| | SR | L = -R | 1kHz | ≥85dB |

| | | | | |
|---|-------|--------|--------|------------|
| 3. Frequency Response 1kHz reference | L | L | 40Hz | 0 ± 0.2 dB |
| | | | 20kHz | 0 ± 0.4 dB |
| | R | R | 40Hz | 0 ± 0.2 dB |
| | | | 20kHz | 0 ± 0.4 dB |
| | C | L = R | 300Hz | 0 ± 0.2 dB |
| | | | 20kHz | 0 ± 0.4 dB |
| | SL/SR | L = -R | 30Hz | 0 ± 0.4 dB |
| | | | 6.5kHz | -3 ± 1 dB |

POWER AMPLIFIER: External 5.1 input = 2V

| | | | |
|------------------------|-------|------------|-------------|
| 1. Output level | All 5 | 1kHz | 2.2 ± 0.3 V |
| 2. THD, with 30kHz LPF | All 5 | 1kHz | ≤0.01% |
| 3. S/N Ratio, A-wtd | All 5 | | ≥90dB |
| 4. Frequency response | All 5 | 20Hz-20kHz | 0 ± 0.2 dB |

PHYSICAL SPECIFICATIONS:

Size (W x H x D) 17 3/4 x 3 7/8 x 11 1/4"

□□(450 x 97 x 285 mm□□)

Net weight 11 lbs (4.99kg)

Shipping weight 13 lbs (5.89kg)

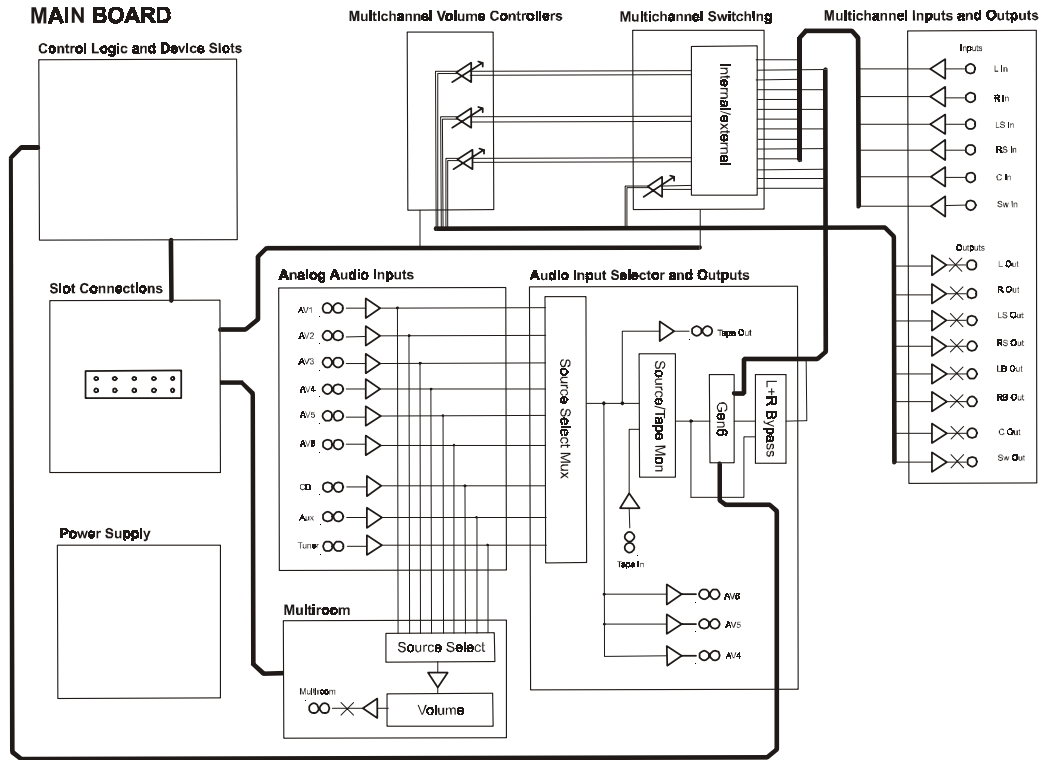

BLOCK DIAGRAM

VIDEO BOARD

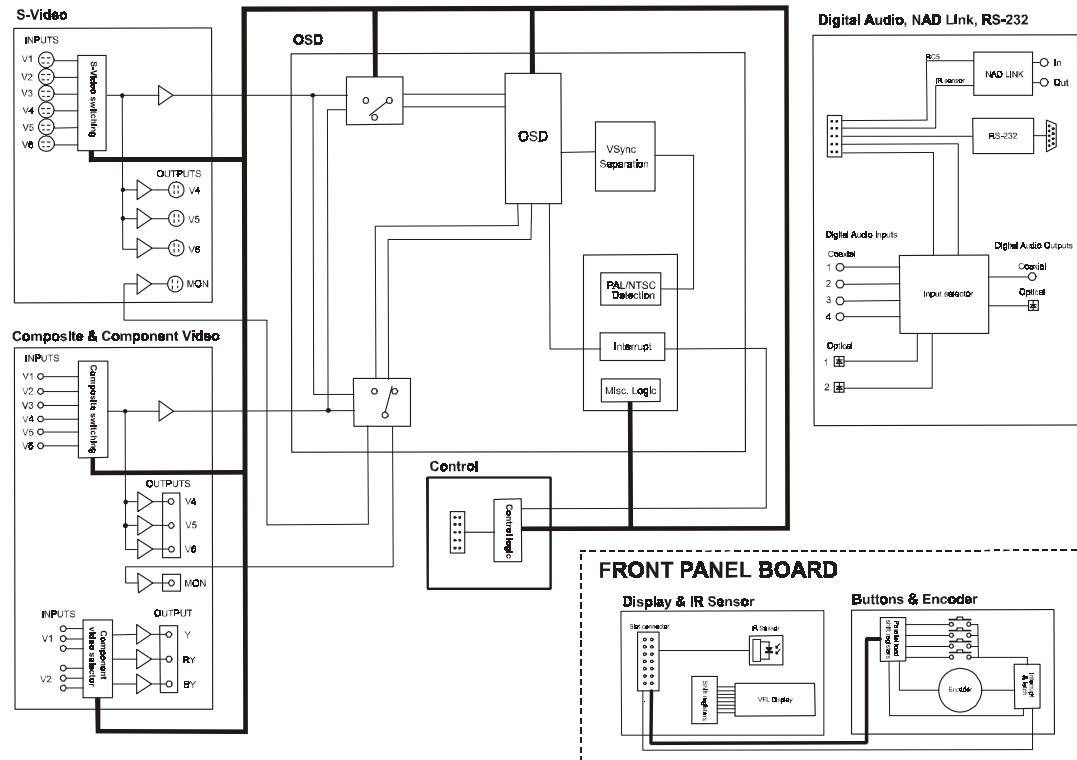

Video & Digital I/O schematics

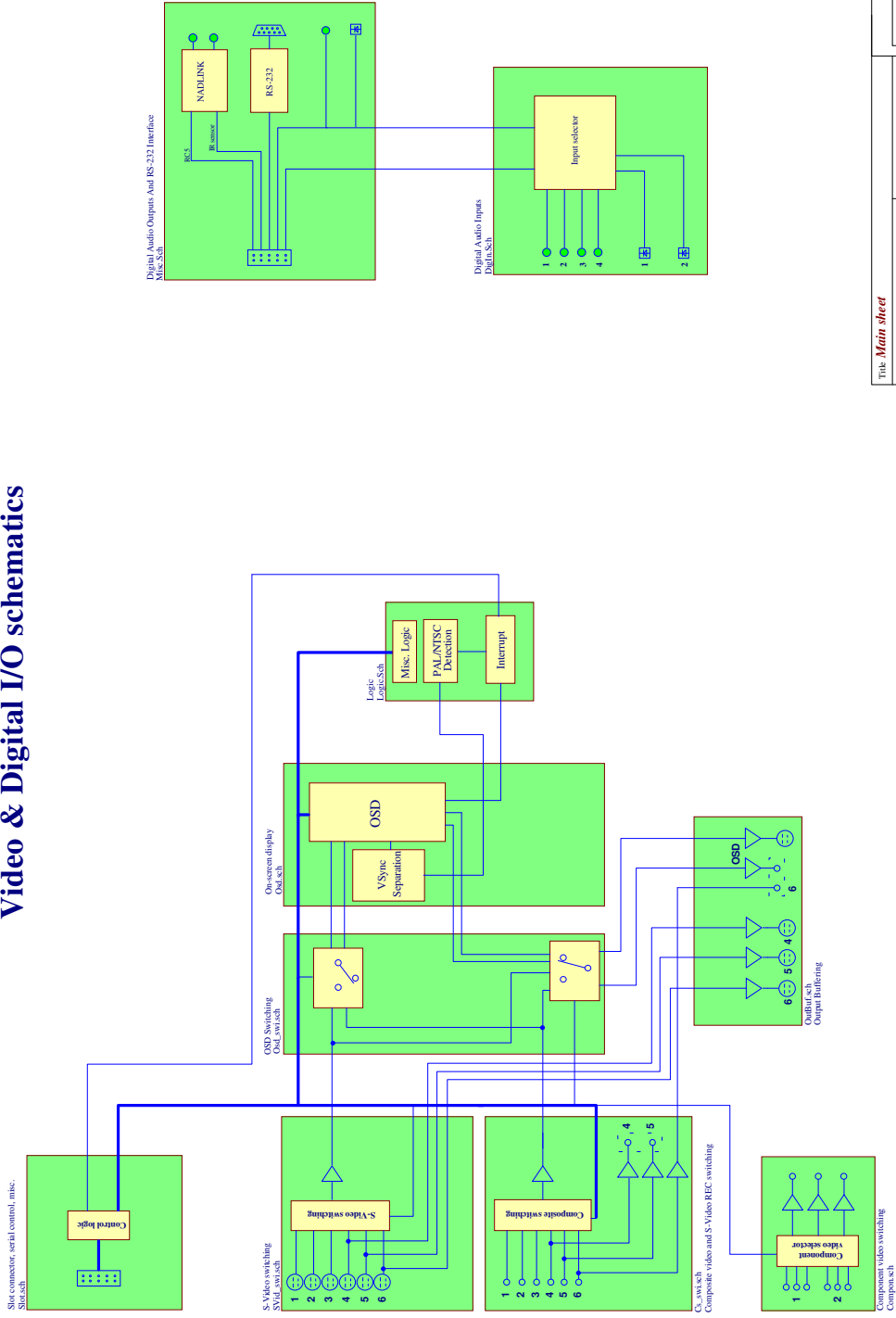

| | |
|--------------------------|-----------------------------|
| Title: Main sheet | |
| Author: Joan Molyneux | Electronics Design Division |
| Project: NAD S170 | Avonmouth 2 |
| Revision: 2.2b | FINLAND |
| Date: 17-Mar-2002 | Tel: +358208346700 |
| Time: 13:16:11 | Sheet: 4 of 11 |
| Size: A3 | |

File:

KEY BOARD - COMPONENT SIDE

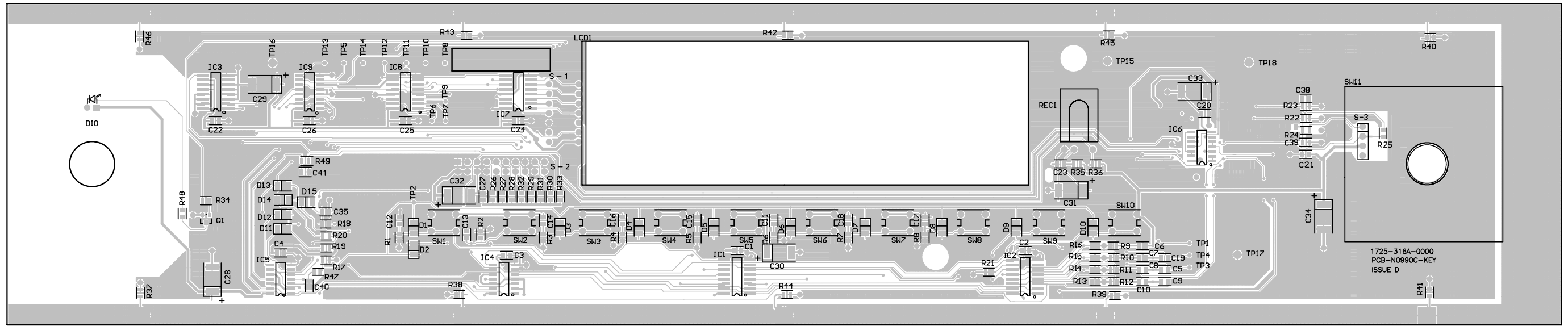

KEY BOARD - SOLDER SIDE

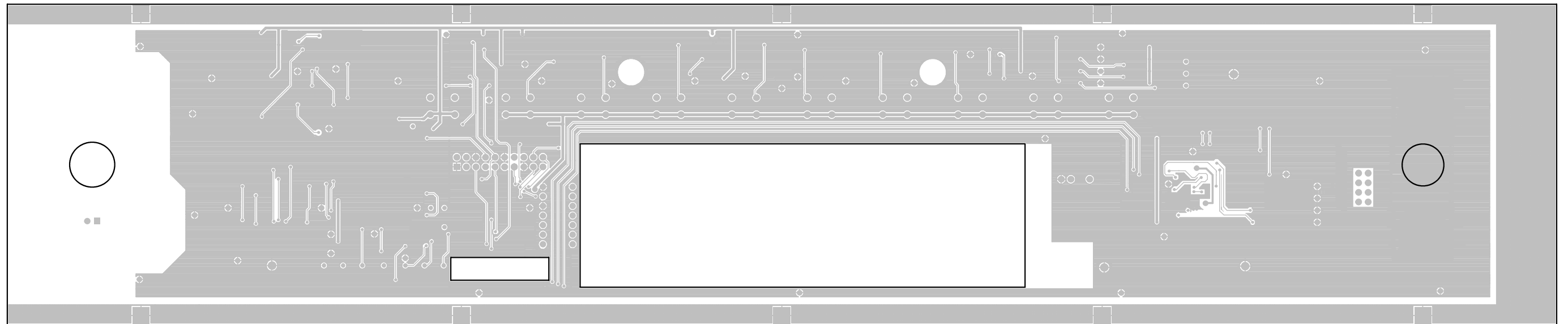

VIDEO BOARD - COMPONENT SIDE

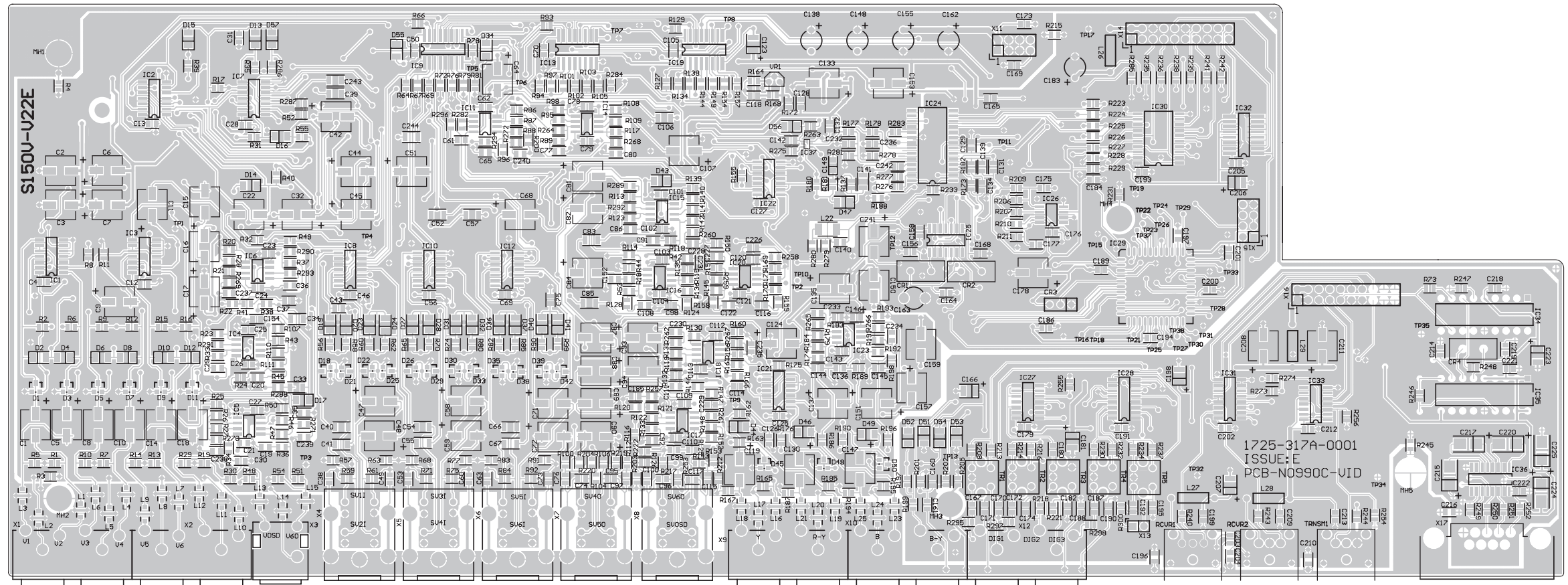

VIDEO BOARD - SOLDER SIDE

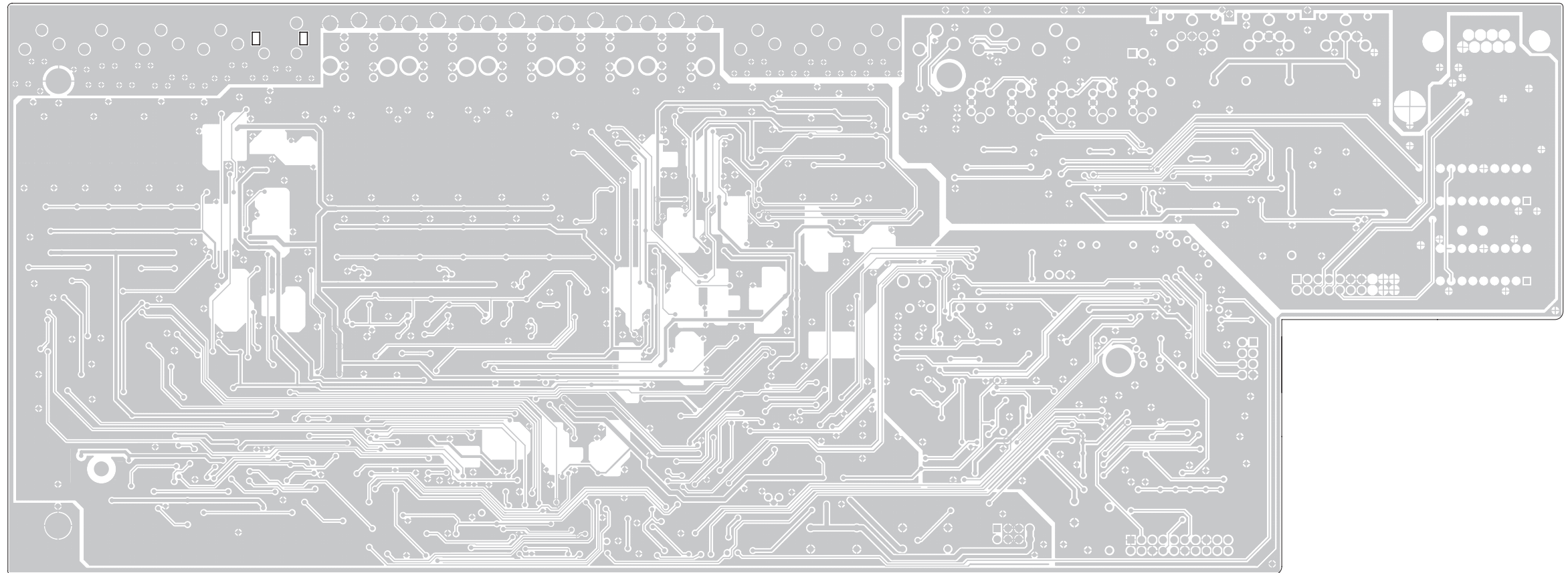

PCB LAYOUT
MAIN BOARD - COMPONENT SIDE

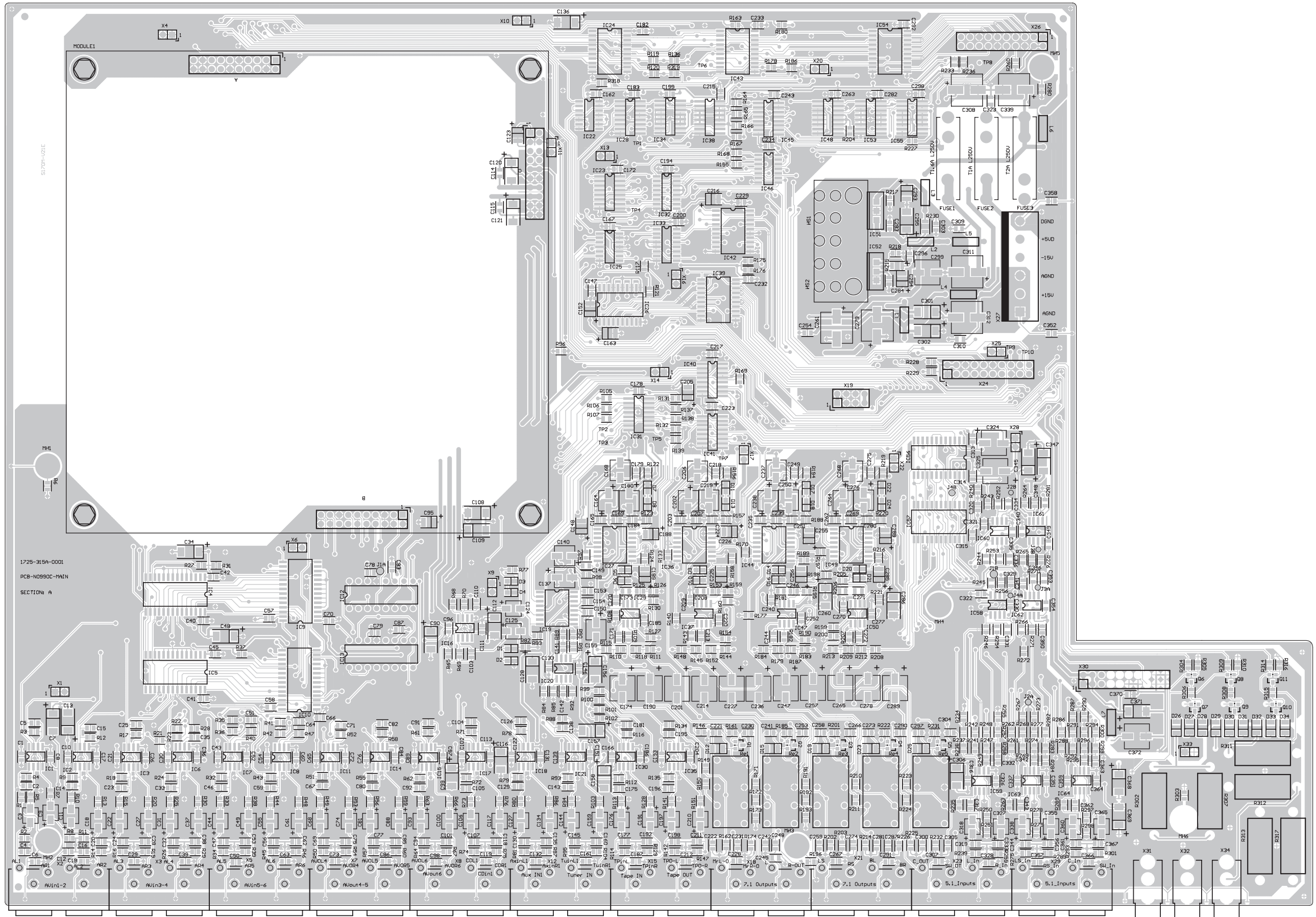

MAIN BOARD - SOLDER SIDE

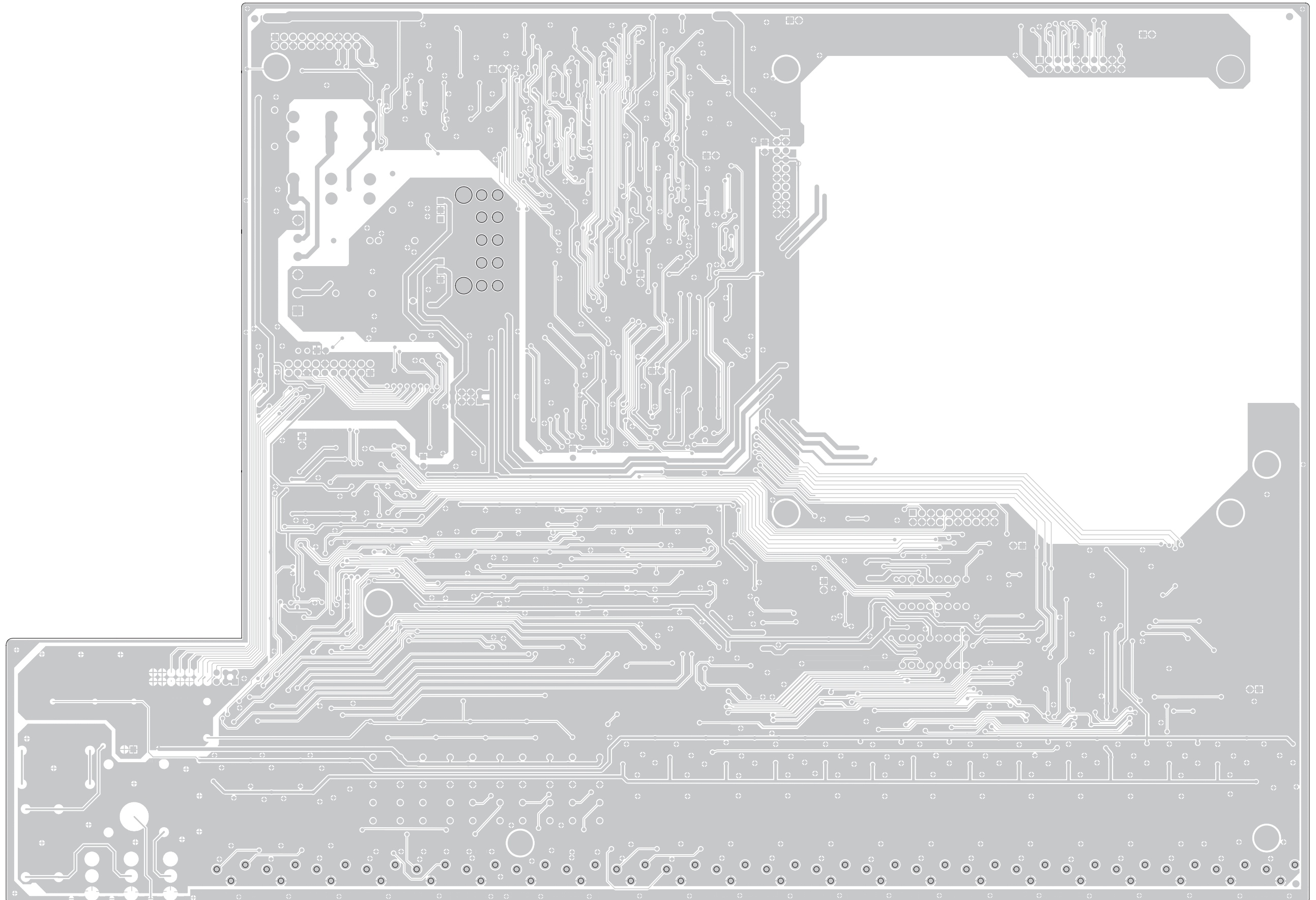

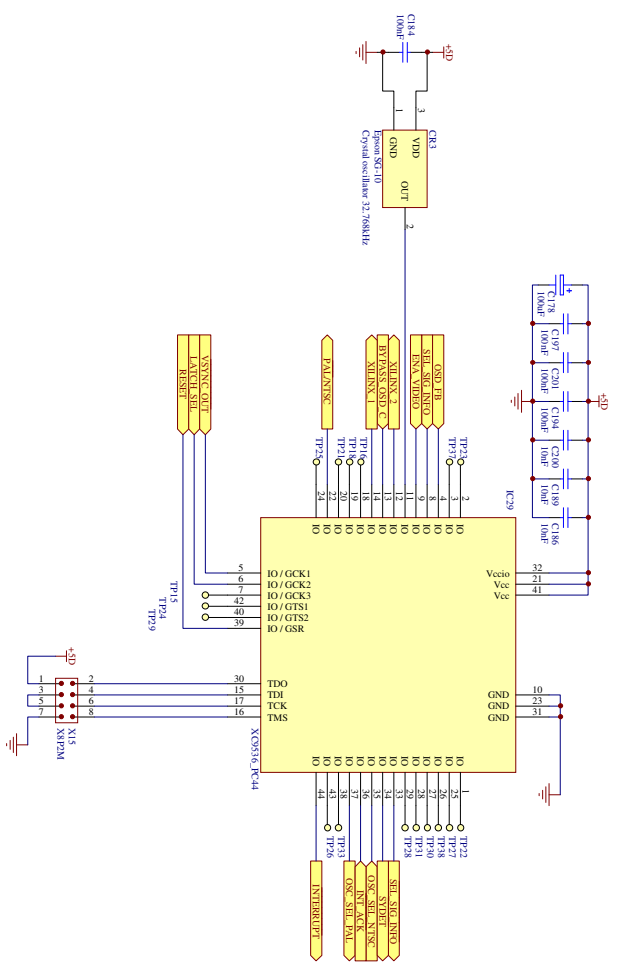

NTSC/PAL detection & miscellaneous logic

| | |
|--|-----------------------|
| Title: NTSC/PAL detection & miscellaneous logic | |
| Author: | |
| Project: NADS170 | |
| Revision: 2.2b | |
| Date: 17-Mar-2002 | Time: 13:17:30 |
| Sheet: A3 | Sheet: of 11 |
| File: | |

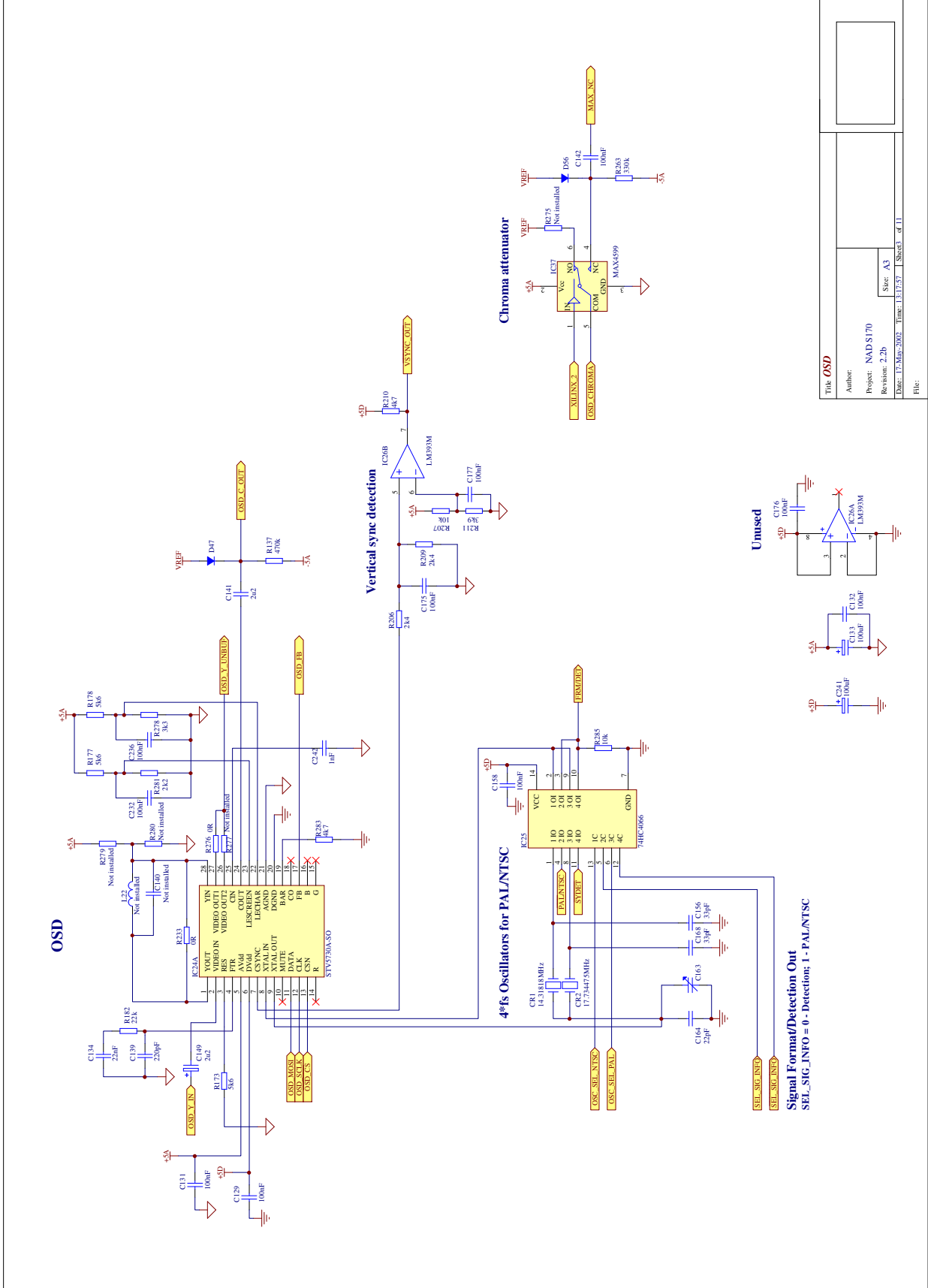

Unused

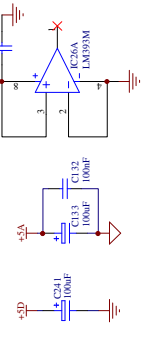

Signal Format/Detection Out
SEL_SIG_INFO = 0 - Detection: 1 - PAL/NTSC

Video OSD output buffers

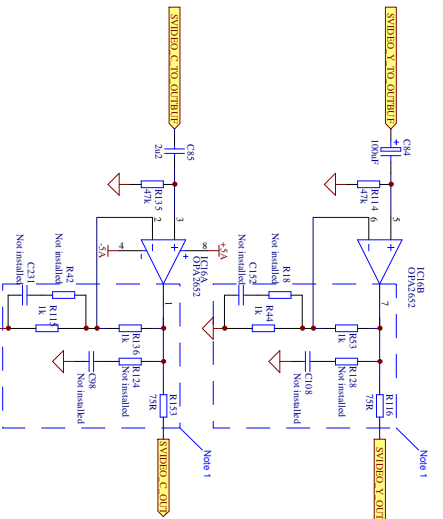

Video 4 output buffers

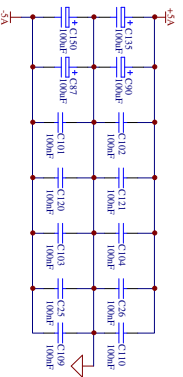
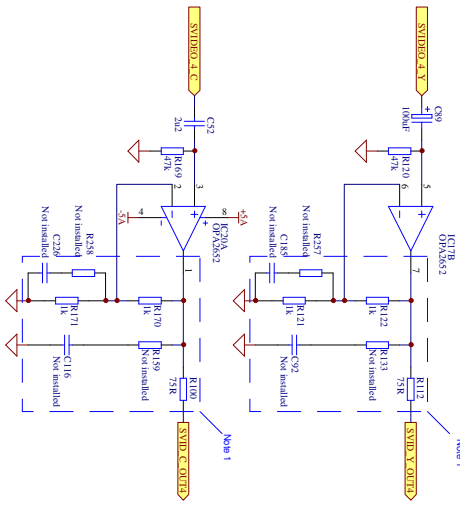

Composite video OSD output buffer

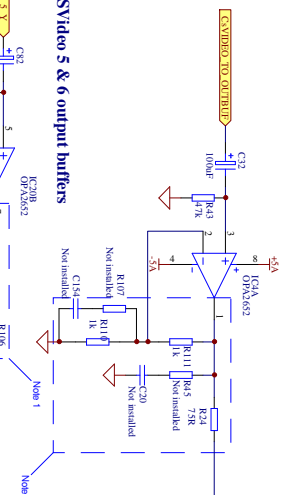

Video 5 & 6 output buffers

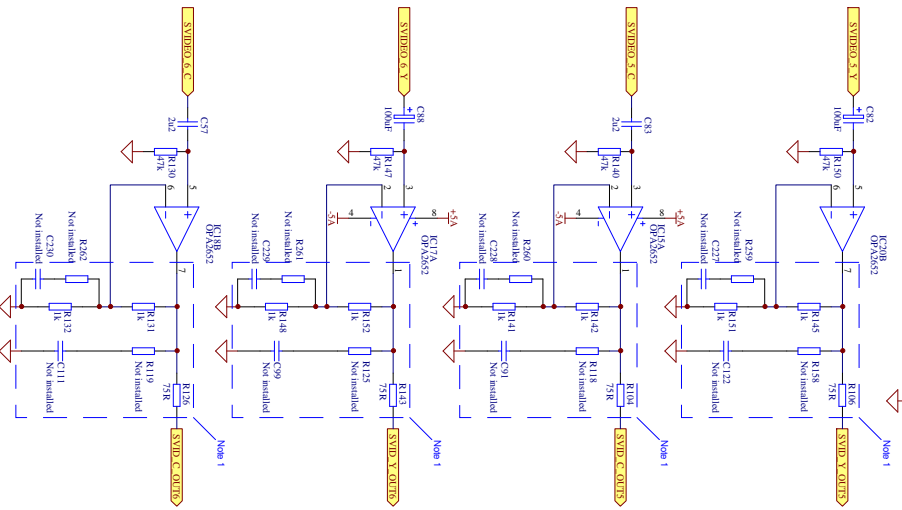

Composite video 6 and OSD outputs

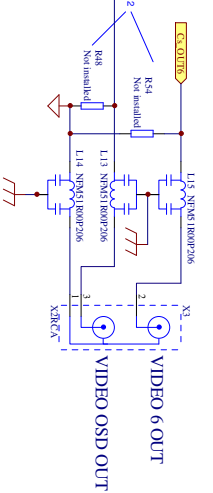

S-Video outputs

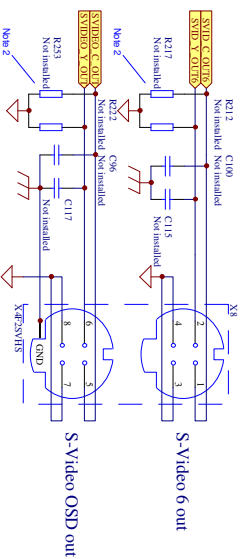
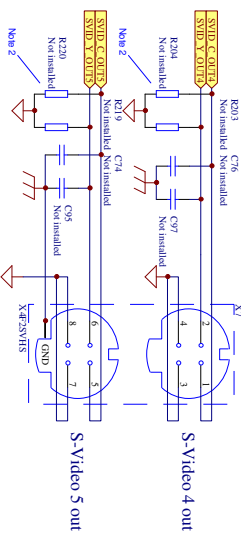

Title: Video & Composite Output Buffers

| | |
|-----------|-------------|
| Author: | |
| Project: | NADS170 |
| Revision: | 2.2b |
| Date: | 17-Mar-2002 |
| Time: | 13:18:37 |
| Sheet: | of 11 |
| File: | |

S-Video inputs

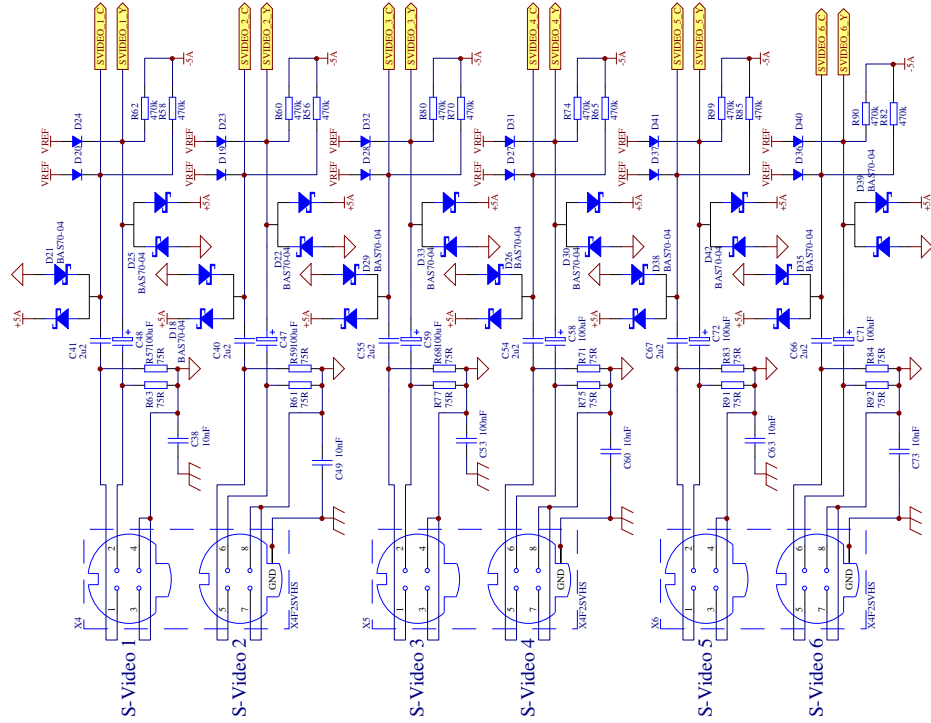

S-Video selector & buffers

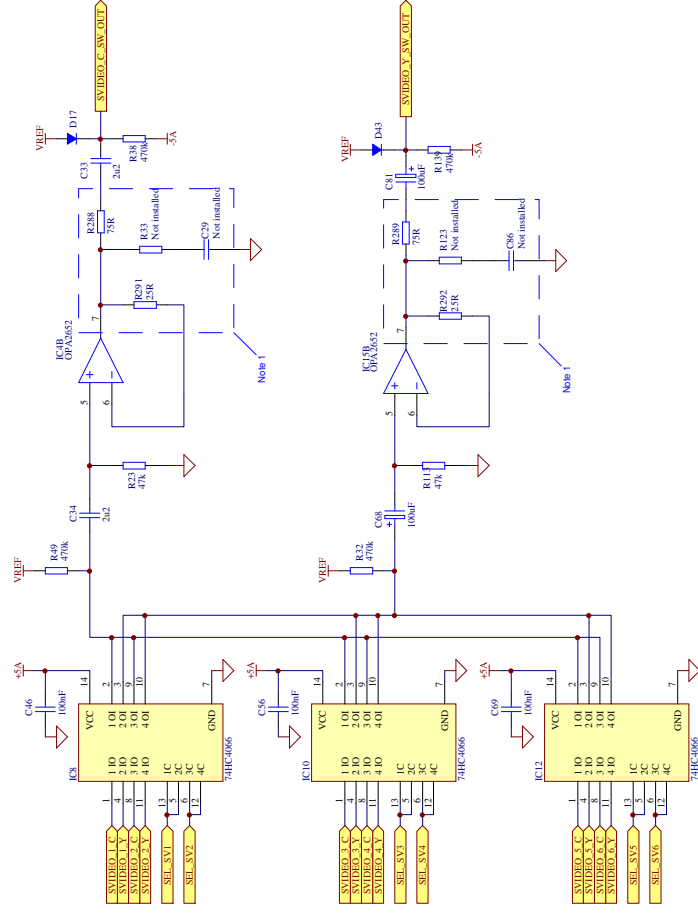

Title: S-Video switching

Author:

Project: NAD S170

Revision: 2.2b

Size: A3

Date: 17-Mar-2002 Time: 13:19:11 Sheet: of 11

File:

Component video selector & buffers

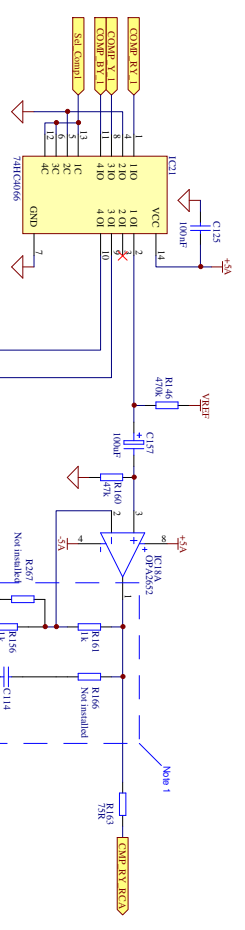

Component video inputs & outputs

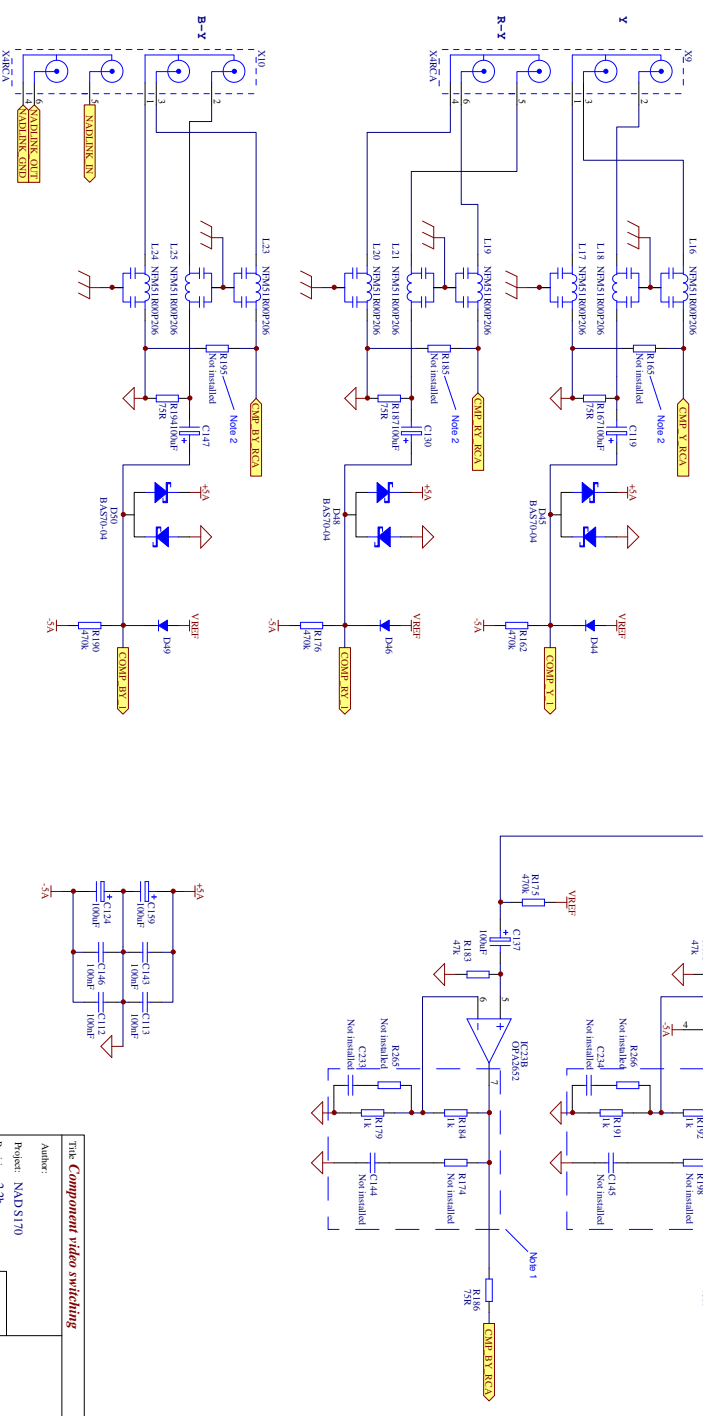

| | |
|---|-------------|
| Title: Component video switching | |
| Author: | |
| Project: | NADS170 |
| Revision: | 2.2b |
| Date: | 17-Mar-2002 |
| Time: | 13:30:07 |
| Sheet: | A3 |
| Sheet: | of 1 |

Slot connector & Control bus buffering

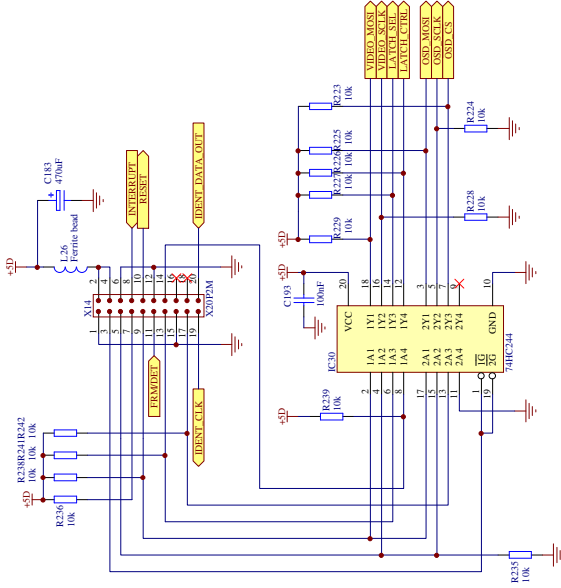

Notes

- Note 1: No PCB groundplane inside this component area
- Note 2: Should be at least 100k if installed

3.4 V reference voltage

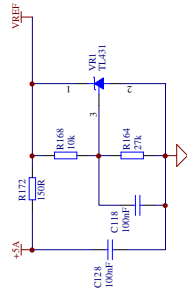

Slot Identification circuit

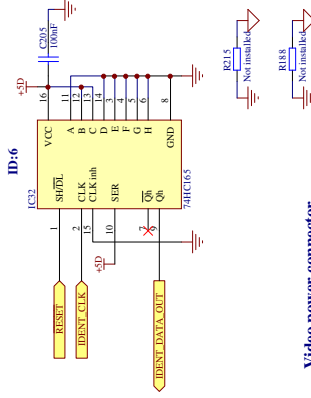

Video power connector

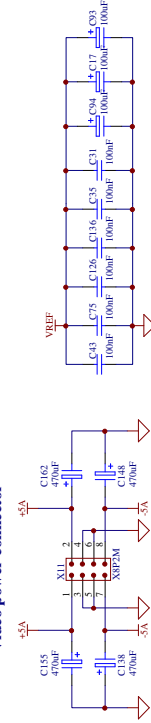

Mounting holes

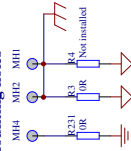

Ground connection should be placed on PCB as close to IC25, IC26 and IC27 as possible.

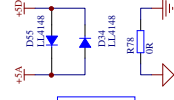

VGND & DGND Testpoints +5D,+5A,-5A Testpoints

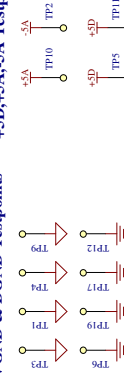

Source selector, REC selector & OSD control signals

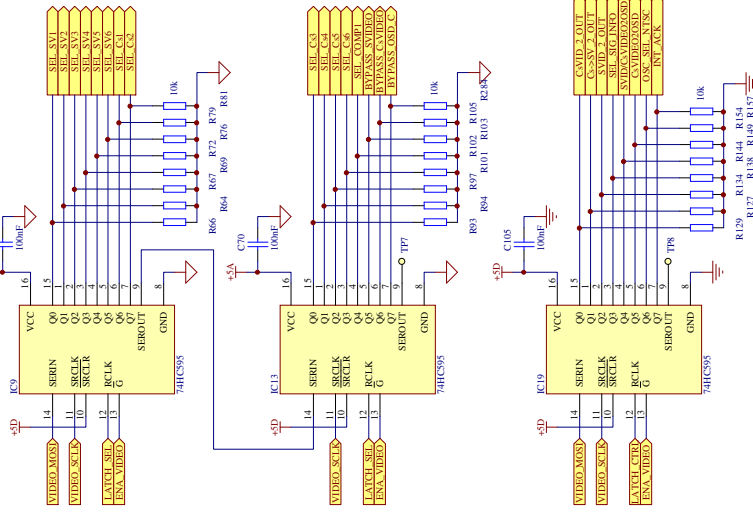

Miscellaneous circuits

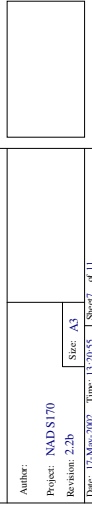

Title: Miscellaneous circuits
Author: NADSI/70
Project: NADSI/70
Revision: 2.2.2b
Date: 17-Mar-2002 Time: 13:20:55 Sheet: of 11

File:

Composite video inputs

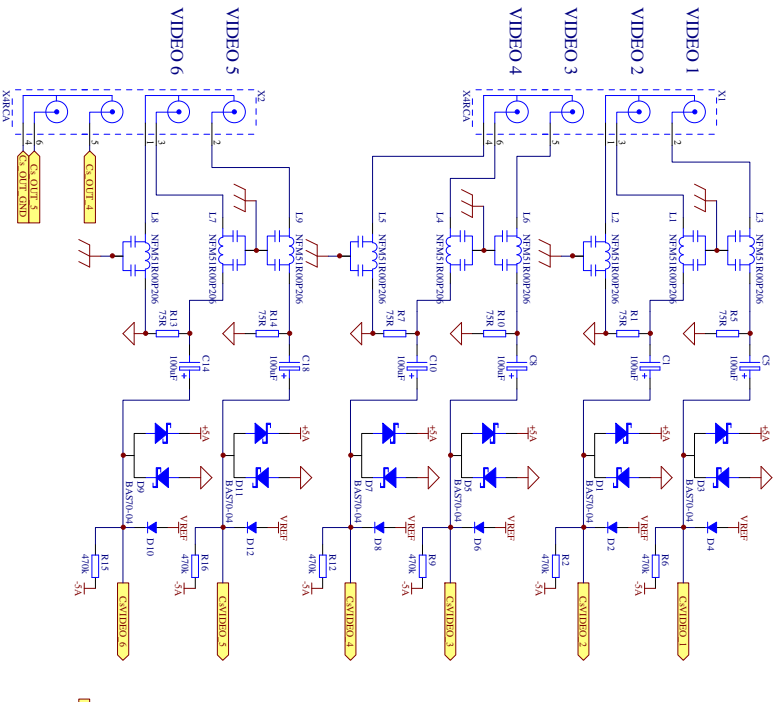

Composite video selectors & buffers

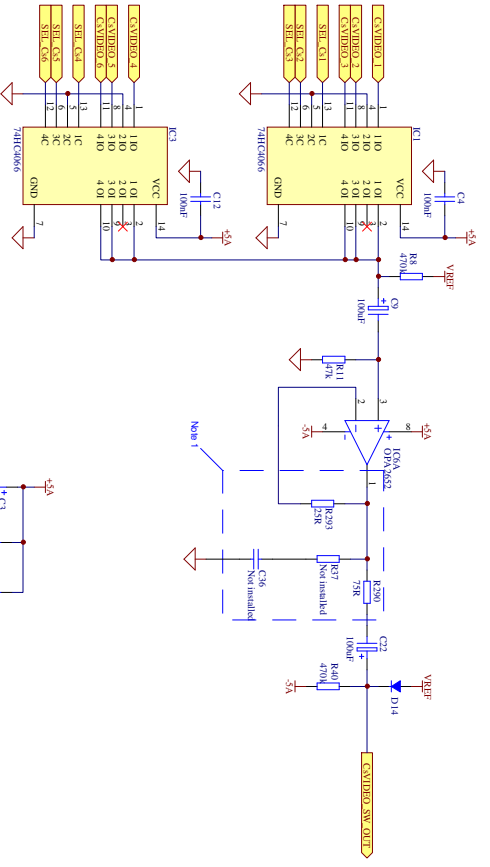

Composite Out Buffering

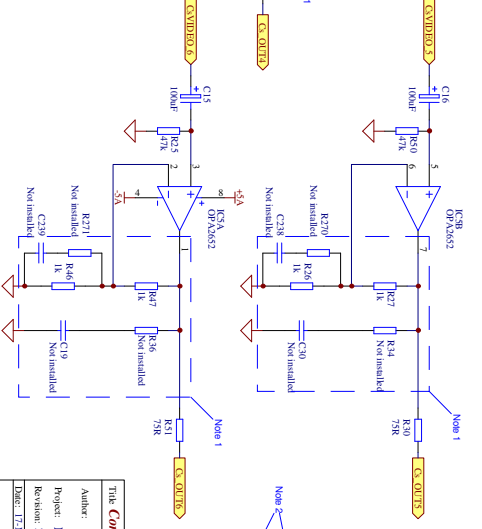

Composite video 4 & 5 outputs

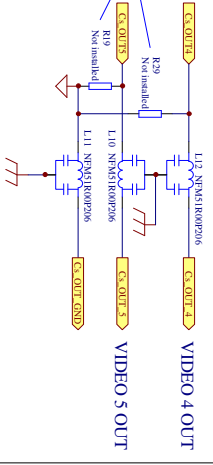

Title Composite video switching

| | |
|---------------------------------|--|
| Title Composite video switching | |
| Author: | |
| Project: | NADS170 |
| Revision: | 2.2b |
| Date: | 17-Mar-2002 Time: 13:13:47 Sheet: 4/11 |
| File: | |

OSD Output Buffering And Switching

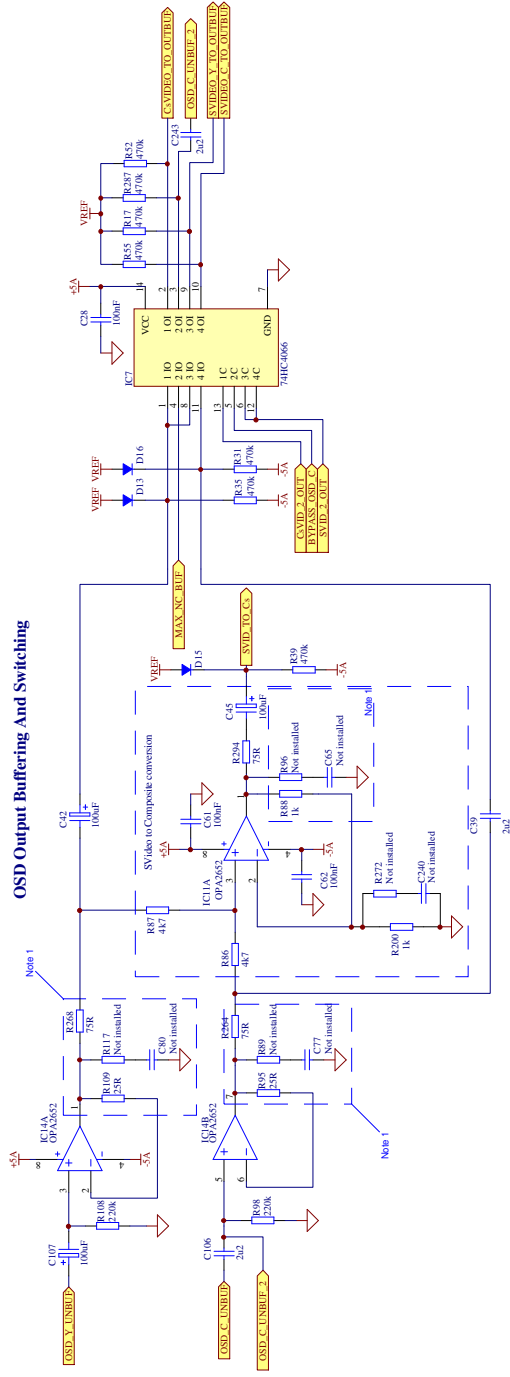

Video Signal Routing to OSD

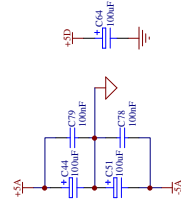
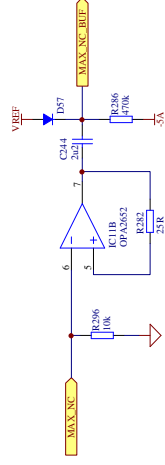
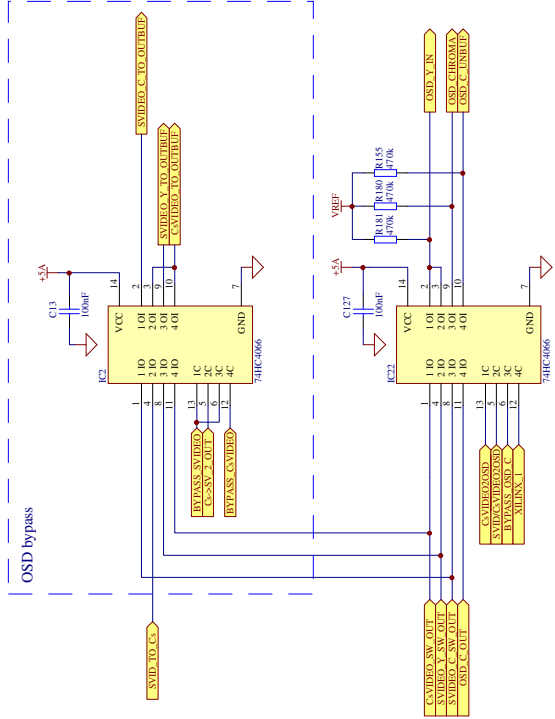

Title OSD Switching

Author:
 Project: NAD S170
 Revision: 2.2b
 Date: 17-Mar-2002 Time: 13:23:33 Sheet: of 11

File:

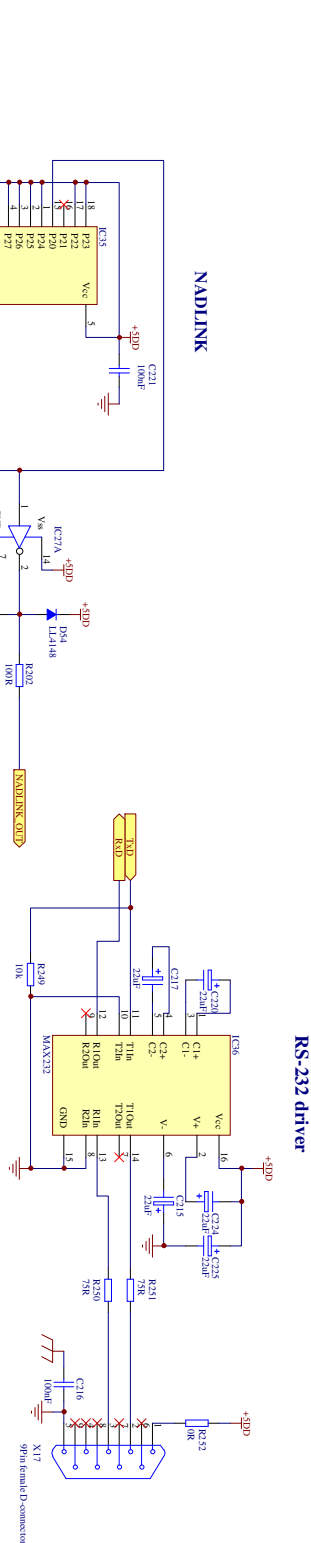

RS-232 driver

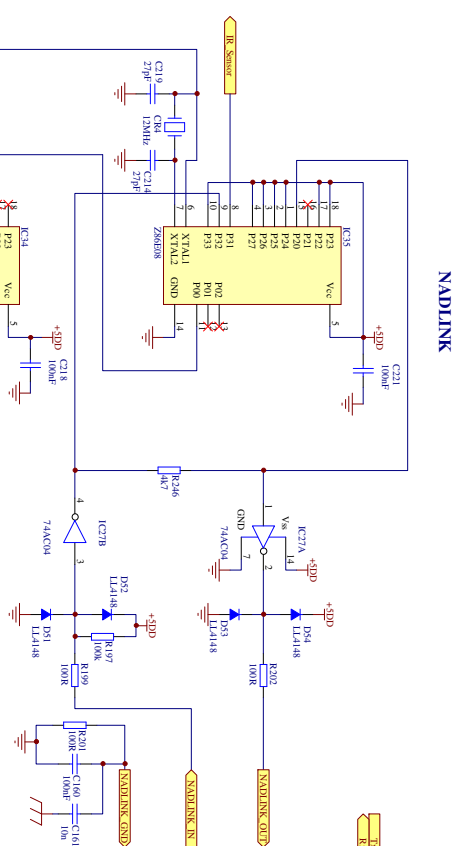

Coaxial and optical outputs



Toslink out 1

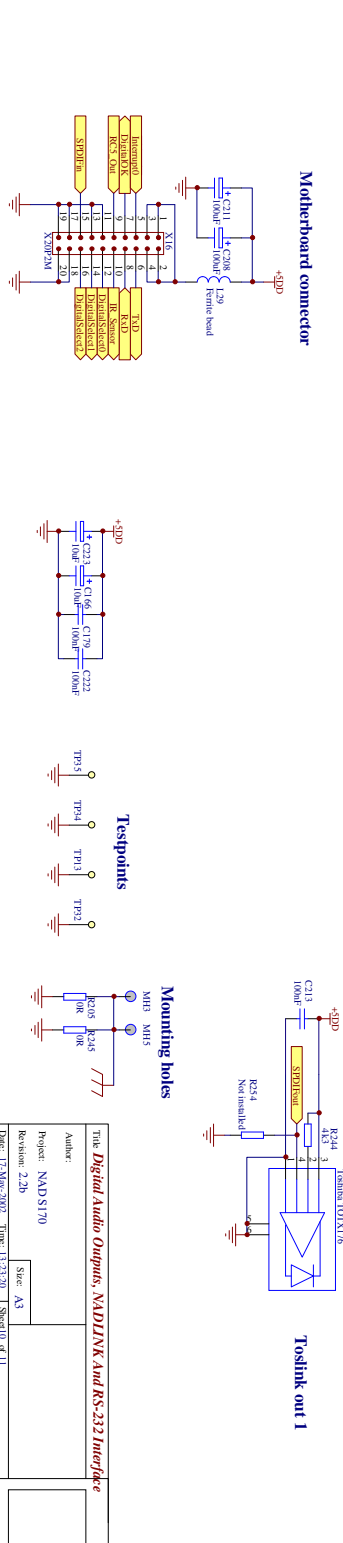

Mounting holes

Testpoints

Motherboard connector

NADLINK

| | |
|---|----------------|
| Title: Digital Audio Outputs, NADLINK And RS-232 Interface | |
| Author: | |
| Project: NADSS170 | |
| Revision: 2.2b | |
| Date: 17-Mar-2002 | Time: 13:37:30 |
| Sheet: A3 | Sheet 1 of 1 |
| File: | |

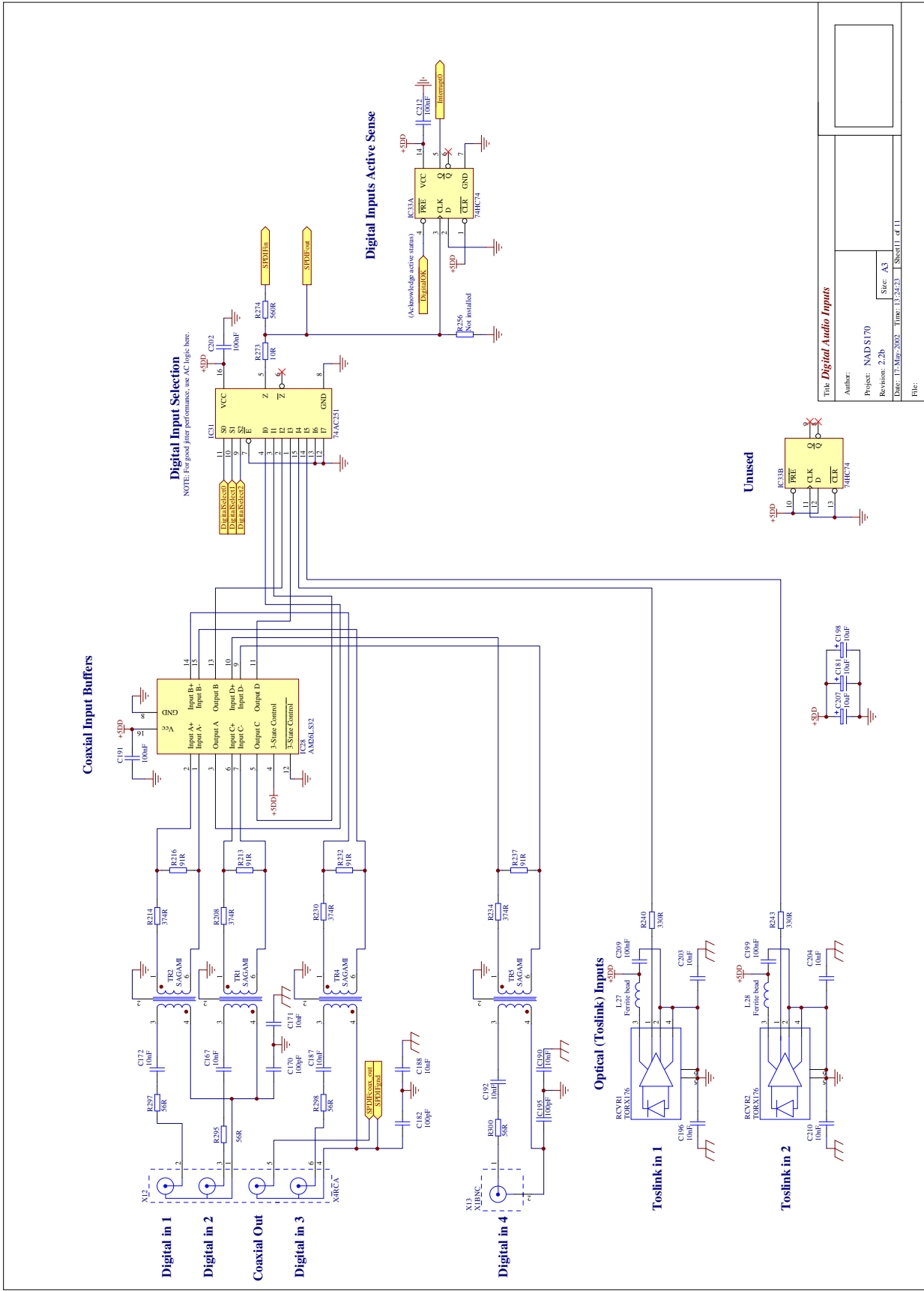

Title: **Digital Audio Inputs**

Author:

Project: NAD S170

Revision: 2.2b

Date: 17-Mar-2002 Time: 13:24:23 Sheet 1 of 1

Size: A3

File:

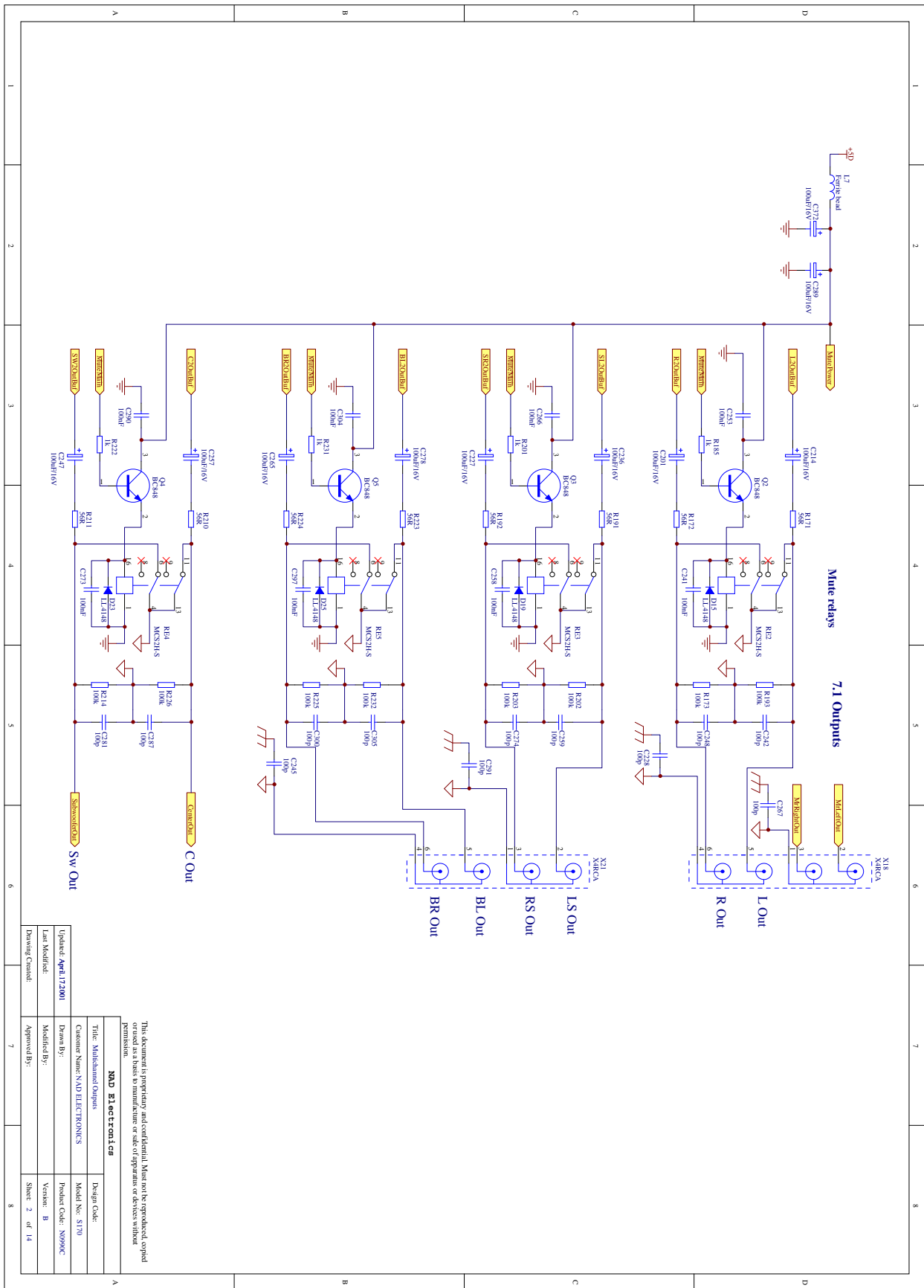

This document is proprietary and confidential. Must not be reproduced, copied, or disseminated in any form or by any means without the prior written permission of MND Electronics.

| | |
|----------------------------------|----------------------|
| MND Electronics | |
| Title: Multi-hand Output | Design Code: |
| Customer Name: N.A.O ELECTRONICS | Model No: ST10 |
| Drawn By: | Product Code: SMP90C |
| Modified By: | Version: B |
| Approved By: | Sheet: 2 of 14 |
| Drawing Control: | |

Updated: April 17, 2001
 Last Modified:
 Drawing Control:

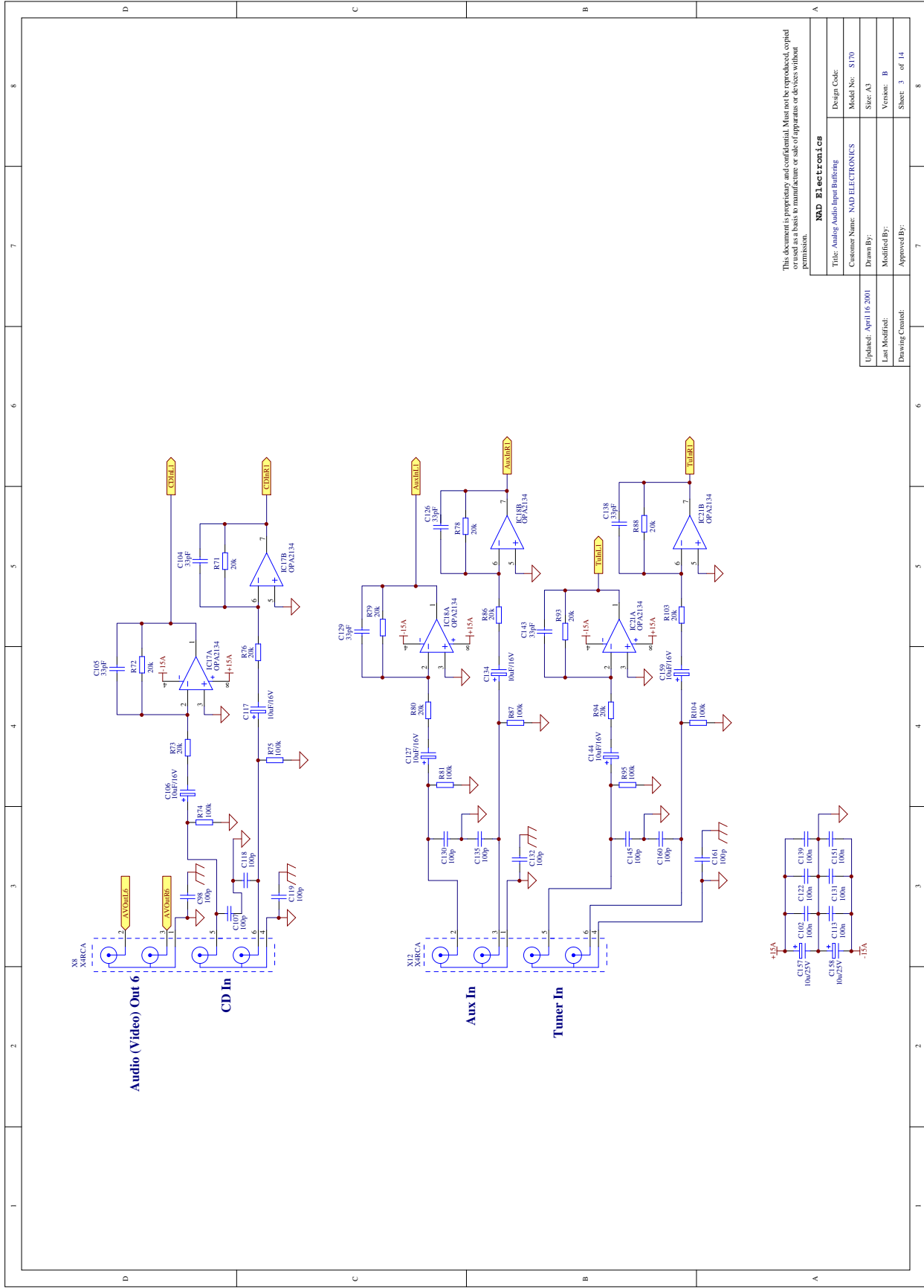

This document is proprietary and confidential. Must not be reproduced, copied or transmitted in any form without the prior written permission of NAD Electronics.

| NAD Electronics | | |
|-------------------------------------|----------------|--|
| Title: Analog Audio Input Buffering | Design Code: | |
| Customer Name: NAD ELECTRONICS | Model No: S170 | |
| Drawn By: | Size: A1 | |
| Last Modified: | Version: B | |
| Approved By: | Sheet: 3 of 14 | |

Updated: April 16, 2001
 Drawing Created:
 Drawing Checked:

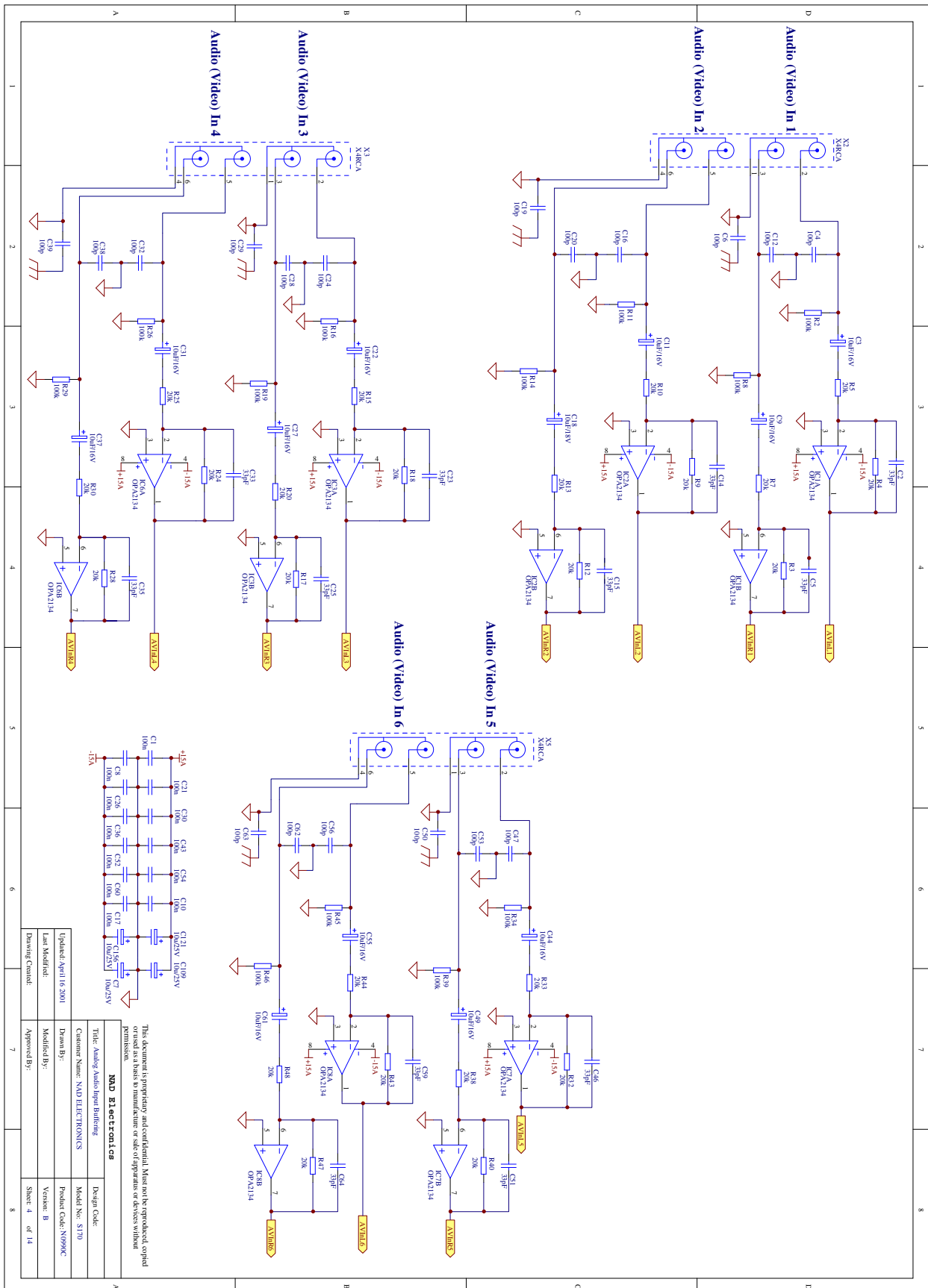

| | | | | | | | | | | | |
|-----|-------|-----|-------|-----|-------|-----|-------|-----|-------|-----|-------|
| C1 | 100n | C21 | 100n | C31 | 100µF | C41 | 100µF | C51 | 100µF | C61 | 100µF |
| C2 | 100n | C22 | 100n | C32 | 100µF | C42 | 100µF | C52 | 100µF | C62 | 100µF |
| C3 | 100n | C23 | 100n | C33 | 100µF | C43 | 100µF | C53 | 100µF | C63 | 100µF |
| C4 | 100n | C24 | 100n | C34 | 100µF | C44 | 100µF | C54 | 100µF | C64 | 100µF |
| C5 | 100n | C25 | 100n | C35 | 100µF | C45 | 100µF | C55 | 100µF | C65 | 100µF |
| C6 | 100n | C26 | 100n | C36 | 100µF | C46 | 100µF | C56 | 100µF | C66 | 100µF |
| C7 | 100n | C27 | 100n | C37 | 100µF | C47 | 100µF | C57 | 100µF | C67 | 100µF |
| C8 | 100n | C28 | 100n | C38 | 100µF | C48 | 100µF | C58 | 100µF | C68 | 100µF |
| C9 | 100n | C29 | 100n | C39 | 100µF | C49 | 100µF | C59 | 100µF | C69 | 100µF |
| C10 | 100n | C30 | 100n | C40 | 100µF | C50 | 100µF | C60 | 100µF | | |
| C11 | 100µF | C41 | 100µF | C51 | 100µF | C61 | 100µF | | | | |
| C12 | 100µF | C52 | 100µF | C62 | 100µF | | | | | | |
| C13 | 100µF | C63 | 100µF | | | | | | | | |
| C14 | 100µF | | | | | | | | | | |
| C15 | 100µF | | | | | | | | | | |
| C16 | 100µF | | | | | | | | | | |
| C17 | 100µF | | | | | | | | | | |
| C18 | 100µF | | | | | | | | | | |
| C19 | 100µF | | | | | | | | | | |
| C20 | 100µF | | | | | | | | | | |
| C21 | 100µF | | | | | | | | | | |
| C22 | 100µF | | | | | | | | | | |
| C23 | 100µF | | | | | | | | | | |
| C24 | 100µF | | | | | | | | | | |
| C25 | 100µF | | | | | | | | | | |
| C26 | 100µF | | | | | | | | | | |
| C27 | 100µF | | | | | | | | | | |
| C28 | 100µF | | | | | | | | | | |
| C29 | 100µF | | | | | | | | | | |
| C30 | 100µF | | | | | | | | | | |
| C31 | 100µF | | | | | | | | | | |
| C32 | 100µF | | | | | | | | | | |
| C33 | 100µF | | | | | | | | | | |
| C34 | 100µF | | | | | | | | | | |
| C35 | 100µF | | | | | | | | | | |
| C36 | 100µF | | | | | | | | | | |
| C37 | 100µF | | | | | | | | | | |
| C38 | 100µF | | | | | | | | | | |
| C39 | 100µF | | | | | | | | | | |
| C40 | 100µF | | | | | | | | | | |
| C41 | 100µF | | | | | | | | | | |

| | | |
|-------------------------------------|--|----------------------|
| Title: Analog Audio Input Buffering | | Design Code: |
| Customer Name: NAD ELECTRONICS | | Model No: S110 |
| Drawn By: | | Product Code: N0990C |
| Modified By: | | Version: B |
| Approved By: | | Sheet: 4 of 14 |
| Drawing Control: | | |

This document is proprietary and confidential. Must not be reproduced, copied, or disseminated in any form or by any means without the prior written permission of NAD Electronics.

Updated: April 16, 2001

Last Modified:

Approved By:

Designing Control:

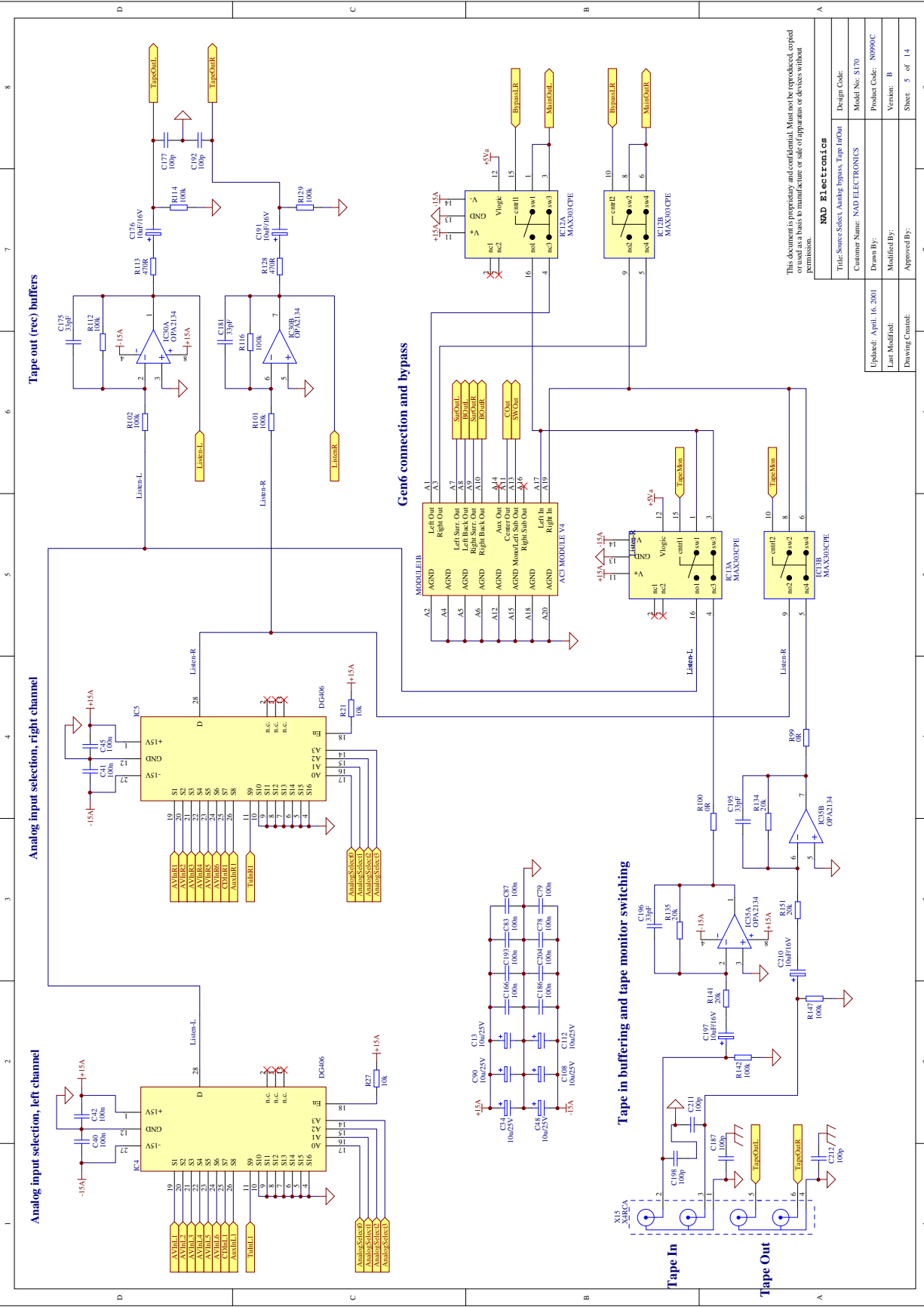

Analog input selection, left channel

Analog input selection, right channel

Tape out (rec) buffers

Genie connection and bypass

Tape in buffering and tape monitor switching

This document is proprietary and confidential. Must not be reproduced, copied or distributed without the prior written consent of NAD Electronics. All rights reserved.

| | |
|--|------------------|
| NAD Electronics | |
| Title: Source Select, Analog Bypass, Tape In/Out | Design Code: |
| Customer Name: NAD ELECTRONICS | Model No: S170 |
| Product Code: N9990C | Version: B |
| Drawn By: | Approved By: |
| Last Modified: | Drawing Created: |
| Updated: April 16, 2001 | Sheet: 5 of 14 |

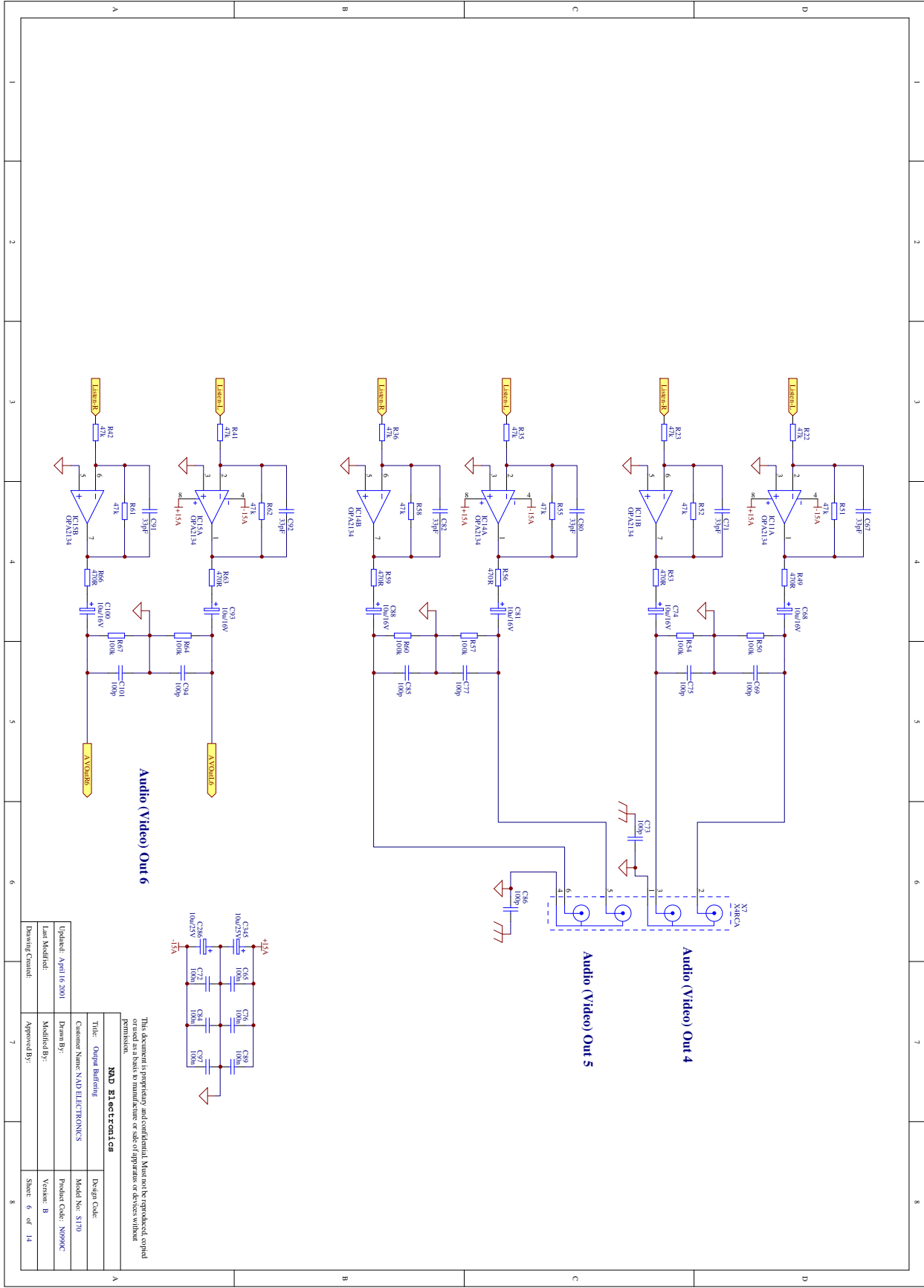

This document is proprietary and confidential. Must not be reproduced, copied, or disseminated in any form or by any means without the prior written permission of NAD Electronics.

| | |
|--------------------------------|---------------------|
| NAD Electronics | |
| Title: Output Buffering | Design Code: |
| Customer Name: NAD ELECTRONICS | Model No: ST10 |
| Drawn By: | Product Code: SN99C |
| Modified By: | Version: B |
| Approved By: | Sheet: 6 of 14 |
| Drawing Control: | |

Audio (Video) Out 6

Audio (Video) Out 4

Audio (Video) Out 5

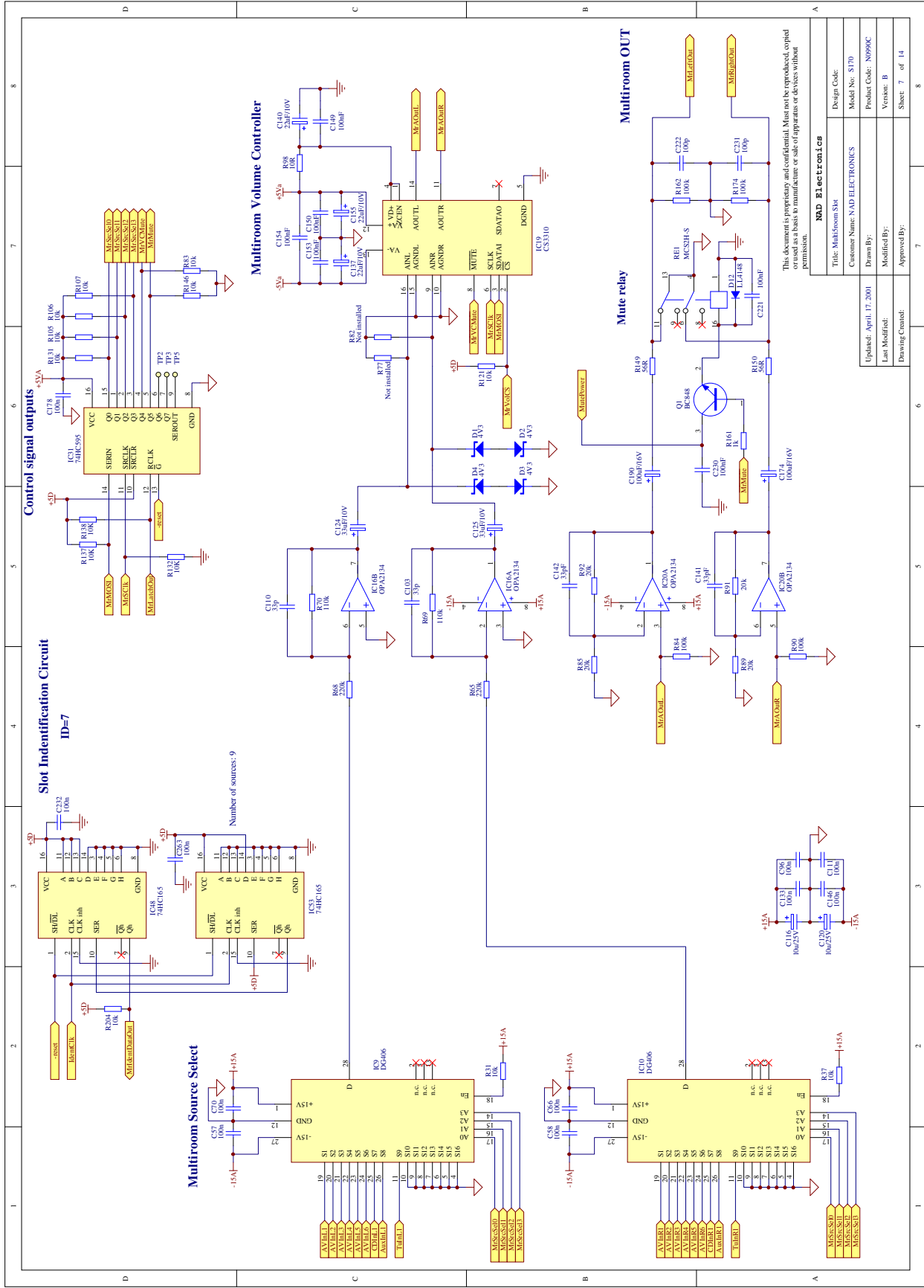

Multiroom Source Select

Slot Identification Circuit
ID=7

Control signal outputs

Multiroom Volume Controller

Mute relay

Multiroom OUT

This document is proprietary and confidential. Must not be reproduced, copied or distributed without the prior written permission of the manufacturer or its authorized representative.

| | |
|----------------|--------------------|
| Design Code: | NAD Electronics CS |
| Title: | Multiroom Sht |
| Customer Name: | NAD ELECTRONICS |
| Model No.: | S170 |
| Product Code: | N0990C |
| Version: | B |
| Drawn By: | |
| Modified By: | |
| Approved By: | |
| Drawing Count: | 7 of 14 |
| Sheet: | 7 of 14 |

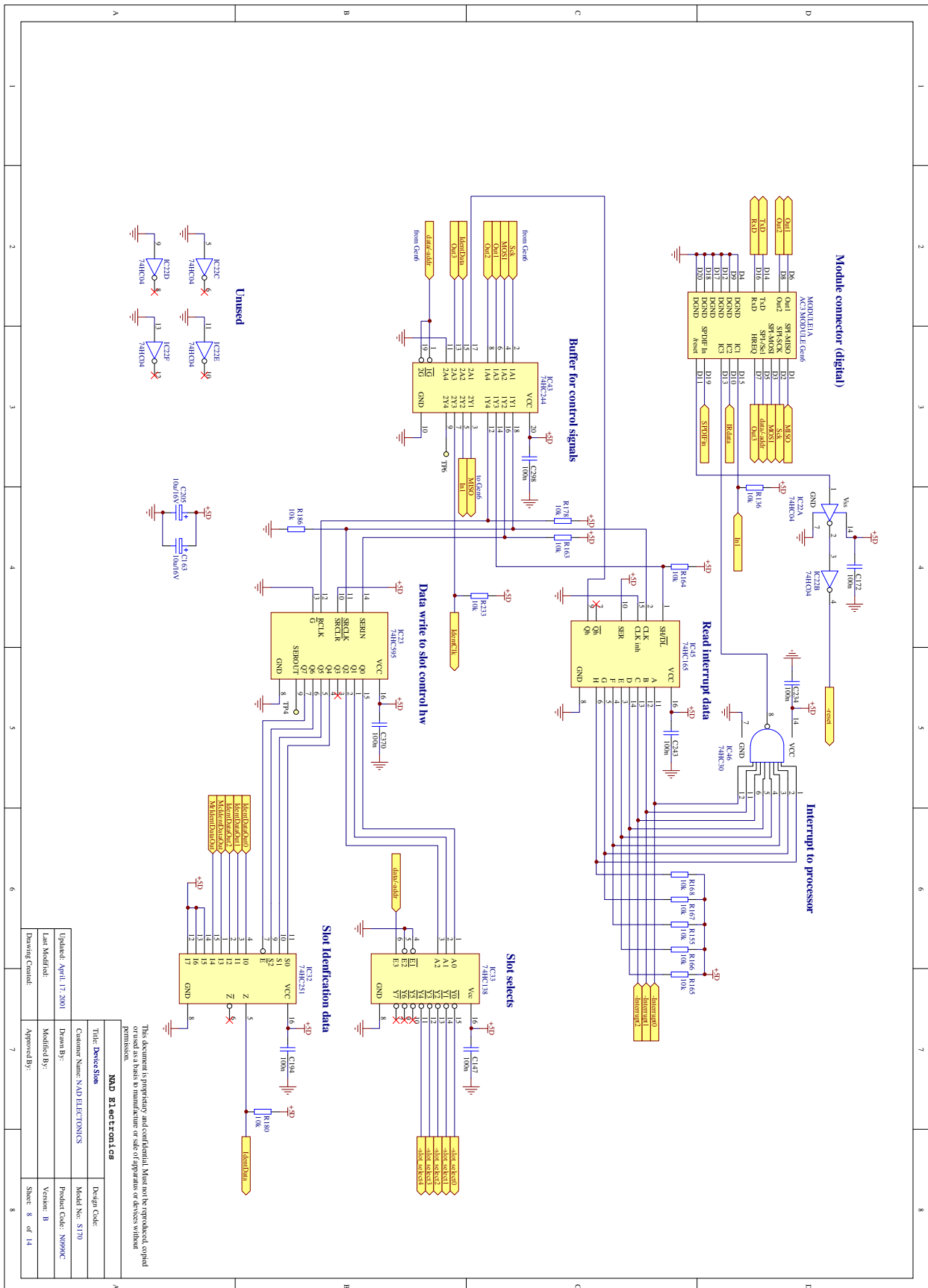

This document is proprietary and confidential. Must not be reproduced, copied or disseminated in any form or by any means without the prior written permission of NAD Electronics.

| | |
|--------------------------------|----------------------|
| NAD Electronics | |
| Title: Device Schem | Design Code: |
| Customer Name: NAD ELECTRONICS | Model No: ST10 |
| Drawn By: | Product Code: SMP99C |
| Modified By: | Version: B |
| Approved By: | Sheet: 8 of 14 |
| Drawing Control: | |

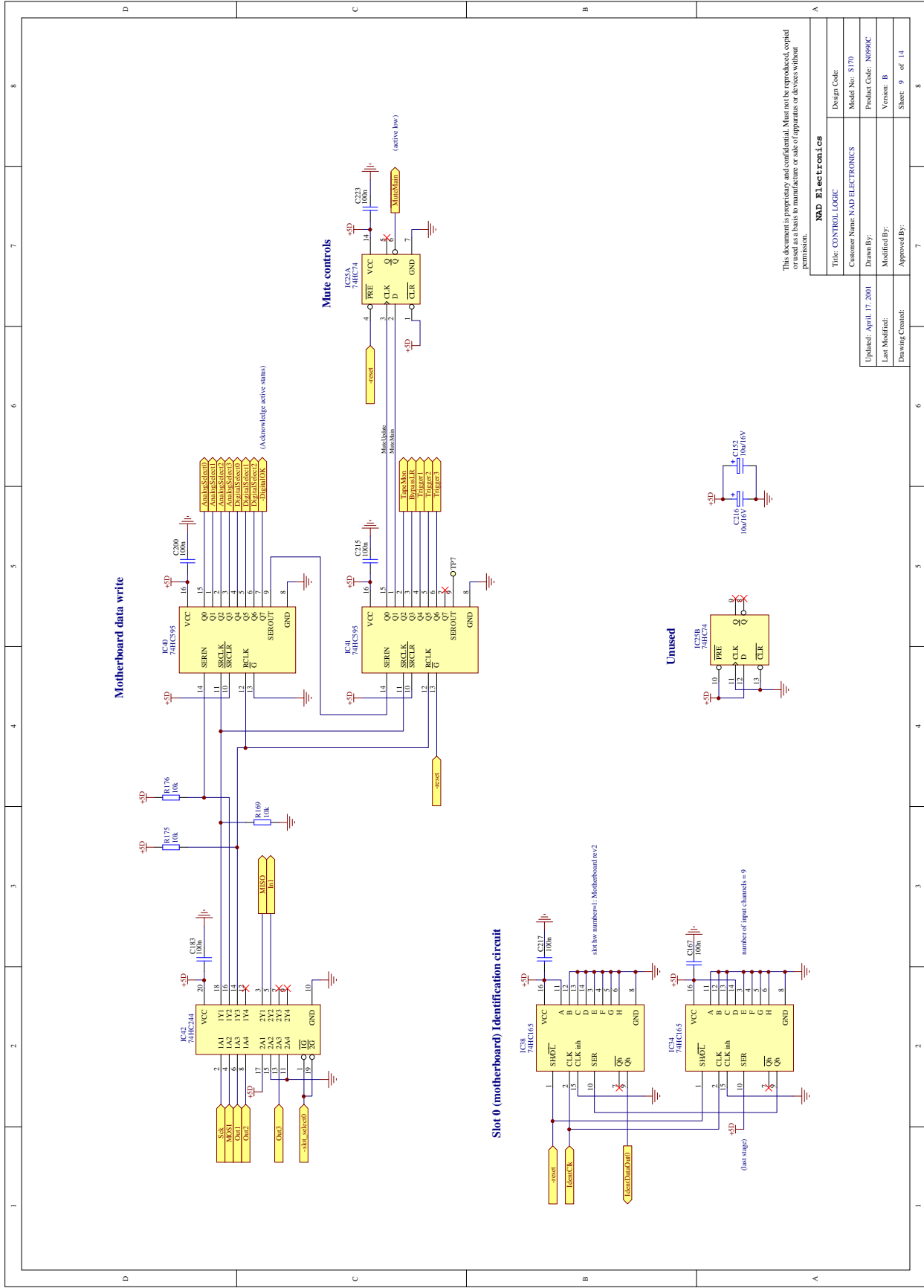

This document is proprietary and confidential. Must not be reproduced, copied or used in any form without the prior written permission of NAD Electronics.

| | |
|--------------------------------|----------------------|
| NAD Electronics | |
| Title: CONTROL LOGIC | Design Code: |
| Customer Name: NAD ELECTRONICS | Model No: S170 |
| Drawn By: | Product Code: N0990C |
| Last Modified: | Version: B |
| Approved By: | Sheet: 9 of 14 |

Updated: April 17, 2001
 Drawing Control:

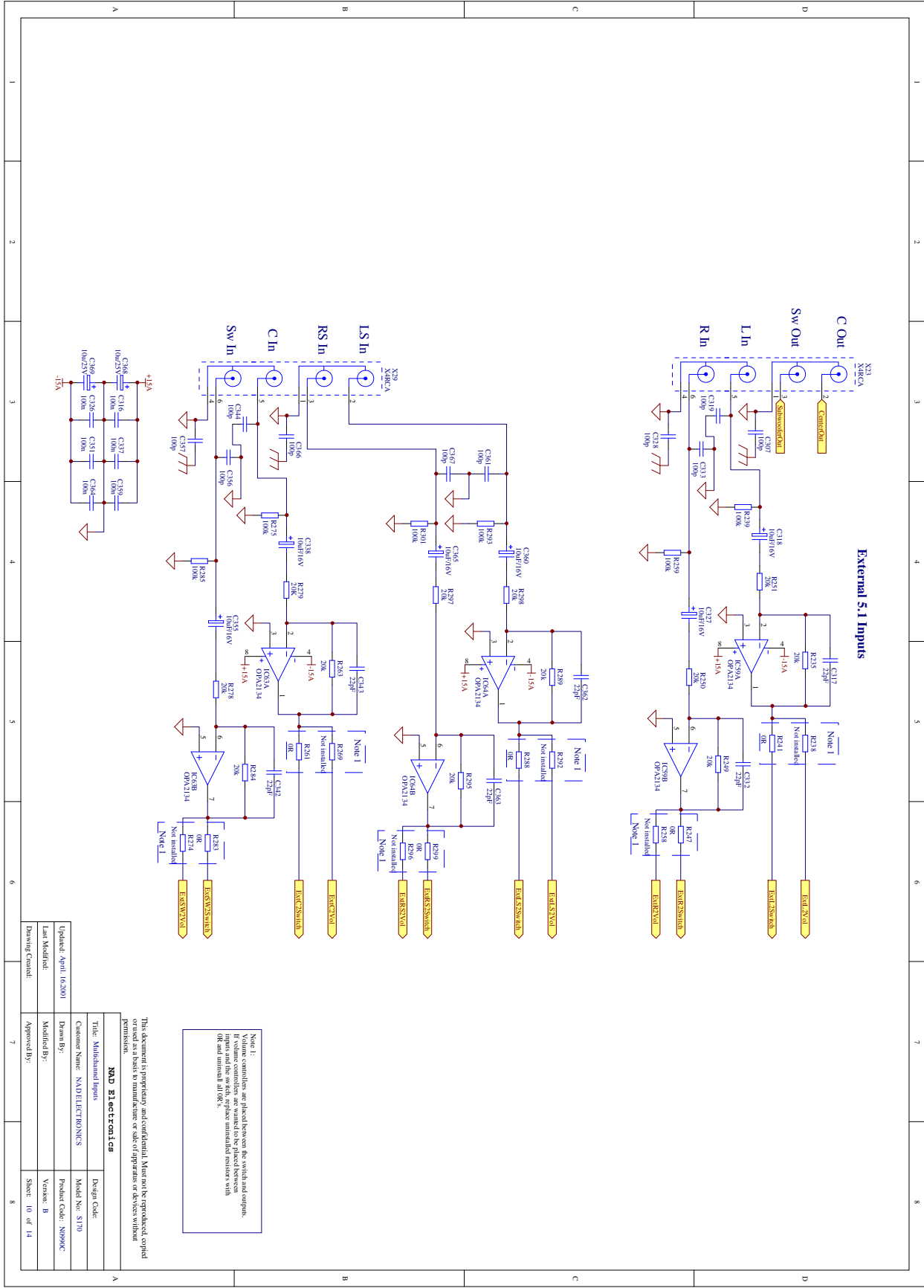

External 5.1 Inputs

Note 1:
 Volume controllers are placed between the switch and outputs.
 If volume controllers are wanted to be placed between inputs and the switch, replace uninstalled resistors with 0Ω or remove all 0Ω's.

This document is proprietary and confidential. Must not be reproduced, copied or disseminated in any form or by any means without permission.

| | |
|--------------------------------|----------------------|
| MND Electronics | |
| Title: Multi-channel Inputs | Design Code: |
| Customer Name: NAD-ELECTRONICS | Model No: ST10 |
| Drawn By: | Product Code: SMP90C |
| Modified By: | Version: B |
| Approved By: | Sheet: 10 of 14 |
| Drawing Control: | |

Device Slot buffers and connectors

Slot 1 (frontpanel)

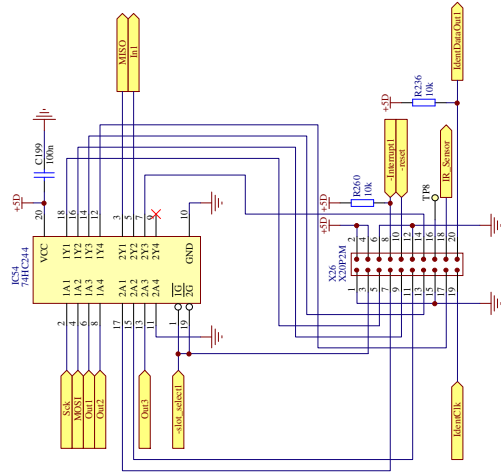

Slot 2 (video board)

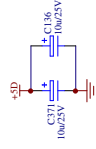
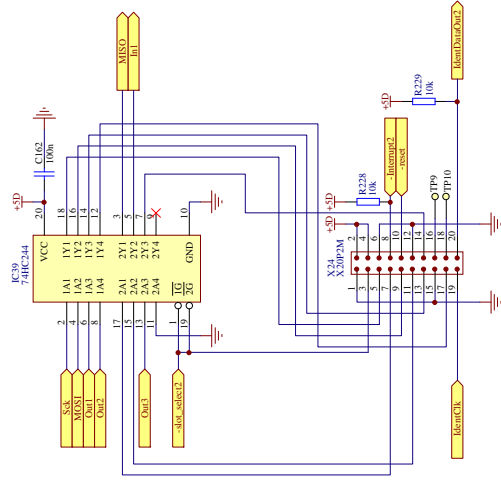

Digital audio connector

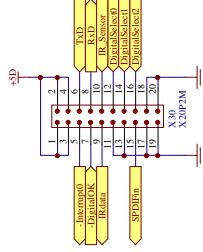

Slot 3 (Multichannel)

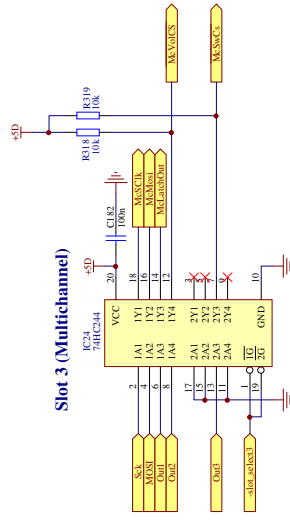

Slot 4 (Multiform)

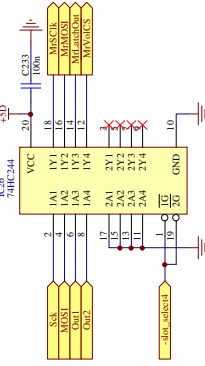

This document is proprietary and confidential. Must not be reproduced, copied or disseminated in any form without the prior written permission of NAD Electronics.

| | | |
|--------------------------------|--------------|----------------------|
| Title: Slot connections | | Design Code: |
| Customer Name: NAD ELECTRONICS | | Model No: S170 |
| Updated: April 17, 2001 | Drawn By: | Product Code: N0990C |
| Last Modified: | Modified By: | Version: B |
| Drawing Count: | Approved By: | Sheet: 11 of 14 |

NAD Electronics

Multichannel Switching

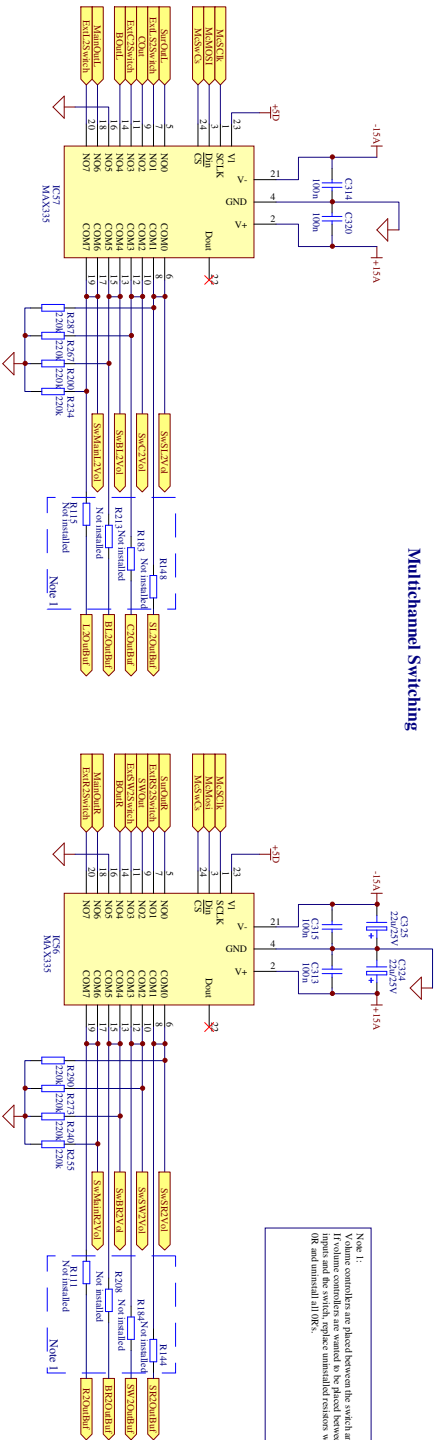

Note 1:
Volume controllers are placed between the switch and outputs.
If volume controllers are wanted to be placed between the switch and the multiplexer, they should be placed between the switch and the multiplexer.

Center & Subwoofer Volume Control

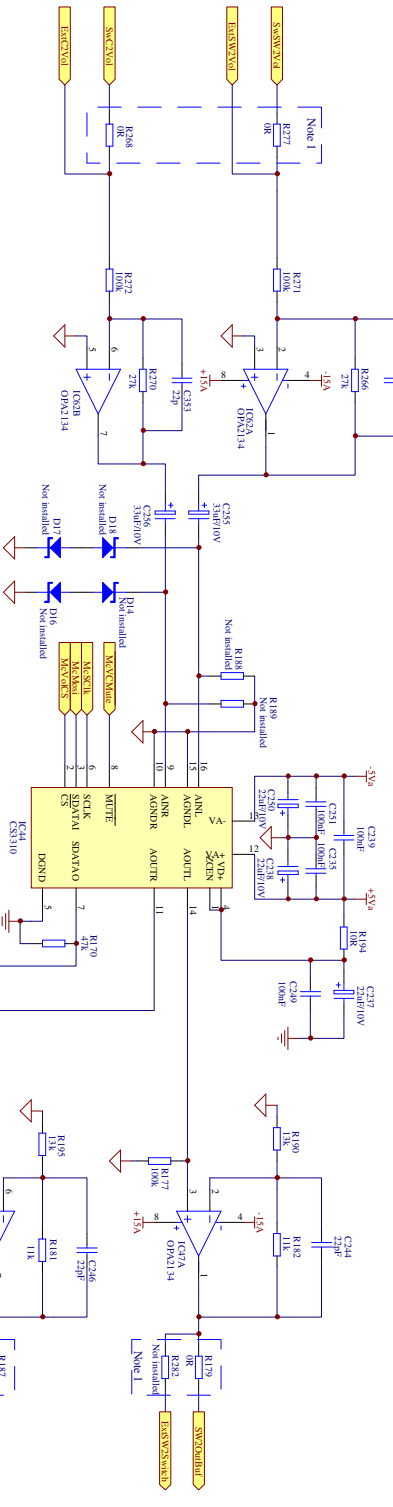

Slot Identification Circuit ID-8

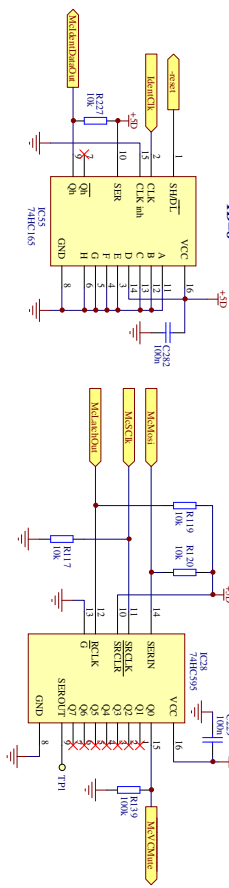

Mute register

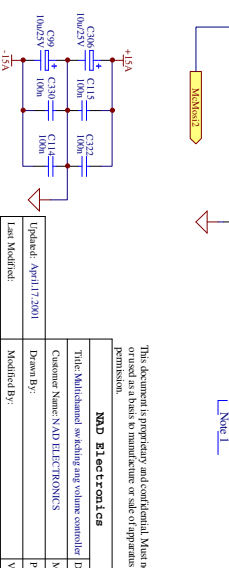

This document is proprietary and confidential. Must not be reproduced, copied, or distributed without the prior written permission of NMD Electronics.

NMD Electronics
 Title: Multichannel switching volume controller
 Design Code: MMD-1000
 Customer Name: N.A.D. ELECTRONICS
 Model No: ST10
 Drawn By: [Blank]
 Product Code: MNP90C
 Modified By: [Blank]
 Version: B
 Approved By: [Blank]
 Drawing Control: [Blank]
 Sheet 12 of 14

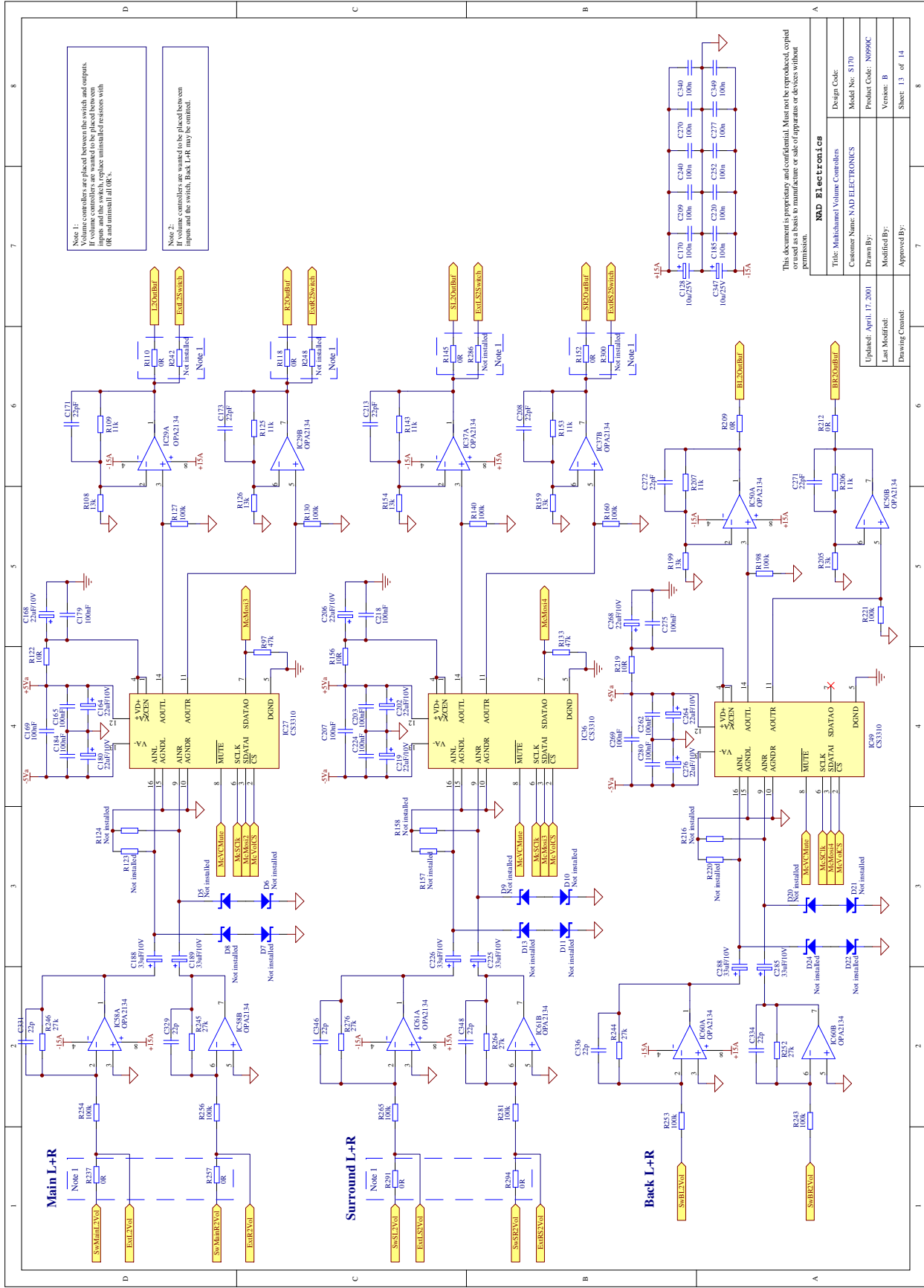

Note 1:
Volume controls are placed between the switch and outputs. If volume controls are placed between the switch and inputs and the switch, replace uninstalled resistors with 0R and uninstall all 0R's.

Note 2:
If volume controls are wanted to be placed between inputs and the switch, Back, L+R may be omitted.

This document is proprietary and confidential. Must not be reproduced, copied or distributed without the prior written permission of NAD Electronics.

| | |
|--|----------------------|
| NAD Electronics | |
| Title: Multichannel Volume Controllers | Design Code: |
| Customer Name: NAD ELECTRONICS | Model No: S170 |
| Drawn By: | Product Code: N0990C |
| Last Modified: | Version: B |
| Modified By: | Approved By: |
| Drawing Count: | Sheet: 13 of 14 |

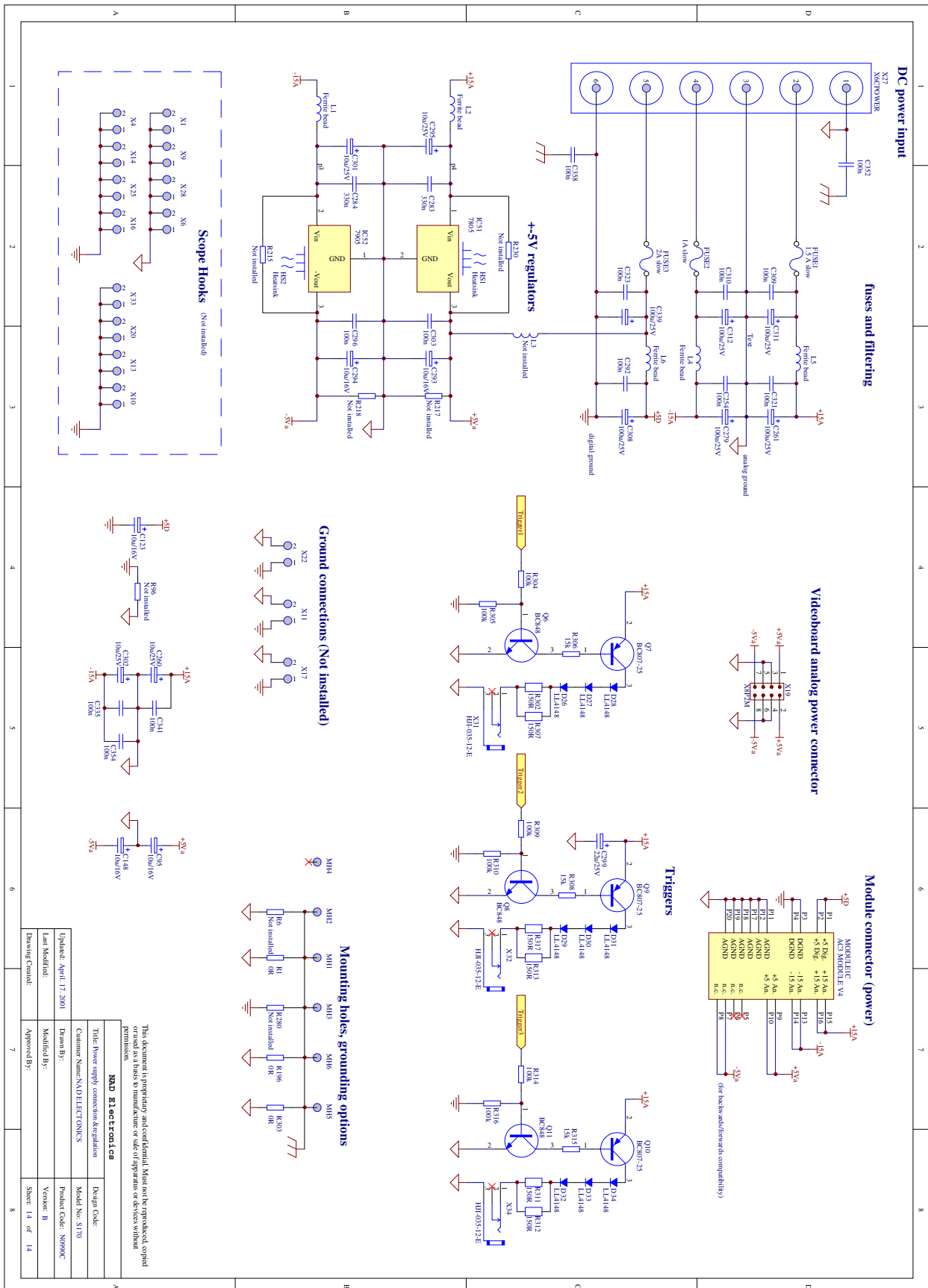

This document is proprietary and confidential. Must not be reproduced, copied, or disseminated in any form or by any means without the express written permission of MMD Electronics.

| | |
|---|----------------------|
| MMD Electronics | Design Code: |
| Third Party supply consistent with regulation | Model No: S170 |
| Customer Name: MMD ELECTRONICS | Drawn By: |
| Updated: April 17, 2001 | Product Code: S0990C |
| Last Modified: | Version: B |
| Approved By: | Sheet: 14 of 14 |
| Drawning Control: | |

ELECTRICAL PARTS LIST

| Location | Part Number | Description |
|---------------------|-----------------------|--------------------------|
| <u>PCB ASSY KEY</u> | | |
| <u>PCB BOARD</u> | | |
| 2000 | PCB-N0990C-KEY | PCB ASSY KEY |
| <u>CAPACITORS</u> | | |
| C38, C39 | 150F-102K-J-BD | CC 50V 1000pF 10% 0805 1 |
| C40 | 150F-103K-J-BD | CC 50V 0.01U 10% 0805 |
| C1-C7, C9-C27, C41 | 150F-104K-J-BD | CC 50V 0.1uF 10% 0805 |
| C35 | 150F-223K-J-BD | CC 50V 0.022U 10% 0805 |
| C28-C34 | 154C-107K-3-HN | CT 10V 100uF 10% SM |
| <u>WAFERS</u> | | |
| S-2 | 2101-0831-0 | WAFER 10PIN P2.54 DUAL |
| S-1 | 2101-1369-0 | CONN.7x2PIN DUAL ROW |
| <u>LCD</u> | | |
| LCD1 | 2460-1450-0 | VF DISPLAY VFD116X37 NOR |
| <u>IC</u> | | |
| IC4, IC5 | 3130-6590-0 | IC 74HC74 DUAL D-TYPE |
| IC9 | 3130-8740-0 | IC 74HC138 SOP PACKAGE |
| IC6 | 3131-9050-0 | IC 74HC00 QUAD 2/P NAND |
| IC7, IC8 | 3131-9500-0 | IC 74HC595AF 8BIT SHIFT |
| IC1, IC2, IC3 | 3131-9520-0 | IC 74HC165AF SHIFT |
| <u>LED</u> | | |
| | 3700-3538-B | LED 3MM FLAT TOP BLUE |
| <u>RESISTOR</u> | | |
| R37-R46 | 4720-000J-J | RMG 1/10W 0R 5% 0805 |

ELECTRICAL PARTS LIST

| Location | Part Number | Description |
|------------------------|------------------------|--------------------------|
| R34 | 4720-102J-J | RMG 1/10W 1K 5% 0805 |
| R18-R21,R26-R33,R49 | 4720-103J-J | RMG 1/10W 10K 5% 0805 |
| R11-R13 | 4720-104J-J | RMG 1/10W 100K 5% 0805 |
| R22,R23 | 4720-124J-J | RMG 1/10W 120K 5% 0805 |
| R24,R25 | 4720-203J-J | RMG 1/10W 20K 5% 0805 |
| R36 | 4720-223J-J | RMG 1/10W 22K 5% 0805 |
| R35 | 4720-331J-J | RMG 1/10W 330R 5% 0805 |
| R48 | 4720-471A-J | RMG 1/10W 470R 1% 0805 |
| R1-R10,R14-R16 | 4720-472J-J | RMG 1/10W 4.7K 5% 0805 |
| R17 | 4720-473J-J | RMG 1/10W 47K 5% 0805 |
| R47 | 4720-682J-J | RMG 1/10W 6.8K 5% 0805 |
| <u>DIODES</u> | | |
| D1-D15 | 4840-1080-3 | RLS-73 DIODE |
| <u>TRANSISTOR</u> | | |
| Q1 | 485C-848C-3 | TR BC848C (1LP) HFE |
| <u>SWITCH</u> | | |
| SW1-SW10 | 5200-3011-0-01 | TACT SWITCH 4P |
| <u>MISCELLANEOUS</u> | | |
| REC1 | 4152-4671-0 | RUBBER PAD 8X8X3 |
| REC1 | 481P-1736-0 | IR RECEIVER TSOP1736 |
| <u>PCB ASSY VOLUME</u> | | |
| <u>PCB BOARD</u> | PCB-N0990C-KEY1 | PCB ASSY VOLUME |
| <u>WAFERS</u> | | |
| J207A | 2101-1375-0 | WAFER 3PIN P2/54 STRIGHT |
| <u>SEMI FIXED</u> | | |
| M301 | 4750-6000-0 | ROTARY ENCODER |

ELECTRICAL PARTS LIST

Location

PCB ASSY MAIN N0990C

PCB BOARD

CAPACITORS

| Part Number | Description |
|---|-------------------------|
| PCB-N0990C-MAIN | PCB ASSY MAIN |
| 150E-334K-J-BD | CC 25V 0.33uF 10% 0805 |
| 150F-101K-J-BD | CC 50V 100P 10% 0805 |
| C283, C284 | |
| C4, C6, C12, C16, C19, C20, C24, C28, C29, C32, C38, C39, C47, C50, C53, C56, C62, C63, C69, C73, C75, C77, C85, C86, C94, C98, C101, C107, C118, C119, C130, C132, C135, C145, C160, C161, C177, C187, C192, C198, C211, C212, C222, C228, C231, C242, C245, C248, C259, C267, C274, C281, C287, C291, C300, C305, C307, C319, C328, C333, C344, C356, C357, C361, C366, C367, | |
| C101, C111, C113, C136, C140, C301, C302, C310, C322, C350, C380, C381, C386, C401, C403-C405, C412, C417, C501-C505, C521, C526, C528, C532, C534, C535, C540-C543, C703 | |
| 150F-104K-5-II | CC 50V 0.1uF 10% RL 5x5 |
| 150F-104K-J-BD | CC 50V 0.1uF 10% 0805 |

ELECTRICAL PARTS LIST

| Location | Part Number | Description |
|---|--|--|
| C153,C154,C162,C165,C166, C167,C169,C170,C172,C178, C179,C182,C183,C184-C186, C193,C194,C199,C200,C203, C204,C207,C209,C215,C217, C218,C220,C221,C223,C224, C229,C230,C232-C235, C239-C241,C243,C249, C251-C253,C254,C258,C262, C263,C266,C269,C270,C273, C275,C277,C280,C282,C290, C292,C296,C297,C298,C303, C304,C309,C310,C313-C316, C320-C323,C326,C330,C335, C337,C340,C341,C349,C351, C352,C354,C358,C359,C364, C370, C343 | 150F-220K-J-BD 150F-330J-J-BD | CC 50V 22P 10% 0805 CC 50V 33pF 5% 0805 1.2x |
| C2,C5,C14,C15,C23,C25, C33,C35,C46,C51,C59,C64, C67,C71,C80,C82,C91,C92 C103-C105,C110,C126,C129, C138,C141,C142,C143, C175,C181,C195,C196, C188,C189,C225,C226, C255,C256,C285,C288 C95,C123,C148,C152,C163, C205,C216,C293,C294, C7,C13,C34,C48,C90,C99 C108,C109,C112,C116,C120, C121,C128,C136,C156-C158, C260,C286,C295,C301,C302, C306,C345,C347,C368,C369, C371, C137,C140,C155,C164,C168, | 154C-336M-3-EF 154D-106M-3-EF 154E-106M-3-FK | CT 10V 33uF 20% SM CT 16V 10uF 20% SM CT 25V 10uF 20% 3.2x6 SM |
| | 157C-226M-3-JJ | CE 10V 22uF 20% 5.3x5.4 |

ELECTRICAL PARTS LIST

| Location | Part Number | Description |
|--|---|---|
| C180, C202, C206, C219, C237, C238, C250, C264, C268, C276 C124, C125 | 157C-336M-3-JJ | CE 10V 33uF 20% 5.3x5.4 |
| C3, C9, C11, C18, C22, C27, C31, C37, C44, C49, C55, C61, C68, C74, C81, C88, C93, C100, C106, C117, C127, C134, C144, C159, C176, C191, C197, C210, C318, C327, C338, C355, C360, C365, C174, C190, C201, C214, C227, C236, C247, C257, C265, C278, C289, C372 C261, C279, C308, C311, C312, C339 | 157D-106M-3-GJK | CE 16V 10uF 20% 4X5.4 SM |
| C299, C324, C325 | 157D-107M-3-MJ | CE 16V 100uF 20% SM |
| C171, C173, C208, C213, C244, C246, C271, C272, C317, C329, C331, C332, C334, C336, C342, C346, C348, C350, C353, C362, C363 | 157E-107M-3-OJ | CE 25V 100uF 20% 8X5.5 |
| WAFERS/JACKS A, C, B X26, X24, X30 X27 X19 X17 X31, X32, X34 X2, X3, X5, X7, X8, X12, X15, X18, X21, X29 X23 | 157E-226M-3-LJ 15CG-220J-J-BD | CE 25V 22uF 20% 6.3X5.4 CTC 0/30 22pF 5% 0805 |
| | 2101-0821-0 2101-0831-0 2101-1367-0 2101-1368-0 2102-8002-3-100 2113-1743-0 2113-1750-0 2113-1756-0 2113-1757-0 | 10 PIN P2.54 CONNECTOR WAFER 10PIN P2.54 DUAL WAFFER 6P P5.0 STRAIGHT REDEPTACLE 8PIN DUAL WAFER 2 PIN 9MM MONO JACK HTJ-035-12E 4P RCA JACK R/W GOLD RCA JACK 4P W/R.BL GOLD RCA JACK 4P BL.W/R GOLD |
| IC IC51 IC52 | 3130-2020-3 3130-6360-0 | IC 7805 REG 5V 1.5A IC 7905 -5V REG 1.5A |

ELECTRICAL PARTS LIST

| Location | Part Number | Description |
|---------------------------------|---------------|--------------------------|
| IC25 | 3130-6590-0 | IC 74HC74 DUAL D-TYPE |
| IC33 | 3130-8740-0 | IC 74HC138 SOP PACKAGE |
| IC19,IC27,IC36,IC44,IC49, | 3130-8860-0 | IC CS3310 STEREO DIGITAL |
| IC4,IC5,IC9,IC10 | 3131-7260-0 | IC DG506A SOP8 SMD |
| IC56,IC57 | 3131-7270-0 | IC MAX335 SOP24 SMD |
| IC24,IC26,IC39,IC42,IC43,IC54 | 3131-7280-0 | IC 74HC244 10x13 SOP20 |
| IC32 | 3131-7290-0 | IC 74HC251 SOP16 |
| IC46 | 3131-7300-0 | IC 74HC30 8-INPUT NAND |
| IC1-IC3,IC6-IC8,IC11,IC14-IC18, | 3131-7310-0 | IC OPA2134 SOP8 SMD |
| IC20,IC21,IC29,IC30,IC35,IC37 | | |
| IC47,IC50,IC58-IC64 | | |
| IC12,IC13 | 3131-7320-0 | IC MAX303CPE SWITCH |
| IC22 | 3131-7340-0 | IC 74HC04 HEX INVERTERS |
| IC31,IC41 | 3131-7570-0 | IC 74HC594 8 bit SHIFT |
| IC28,IC23,IC40 | 3131-9500-0 | IC 74HC595AF 8BIT SHIFT |
| IC34,IC38,IC45,IC48,IC53,IC55 | 3131-9520-0 | IC 74HC165AF SHIFT |
| RELAY | | |
| REL-RE5- | 4500-0420-0 | RELAY MCSS2H-S |
| RESISTOR | | |
| X31C,X32C,X34C | 4715-472A-2 | RMF 1/4W 4.7K 1% AT |
| R302,R307,R311-R313,R317 | 4719-101J-1-P | RMF 2W 100R 5% AL FP |
| R1,R99,R100,R110,R118, | 4720-000J-J | RMG 1/10W 0R 5% 0805 |
| R145,R152,R179,R187,R196, | | |
| R209,R212,R237,R241,R247, | | |
| R257,R261,R268,R277,R283, | | |
| R288,R291,R294,R299,R303, | | |
| R98,R122,R156,R194,R219 | 4720-100J-J | RMG 1/10W 10R 5% 0805 |
| R161,R185,R201,R222,R231 | 4720-102J-J | RMG 1/10W 1K 5% 0805 |
| R21,R27,R31,R37,R83, | 4720-103J-J | RMG 1/10W 10K 5% 0805 |
| R105-R107,R117,R119-R121, | | |
| R131,R132,R136-R138, | | |
| R146,R155,R163-R169, | | |
| R175,R176,R178,R180,R186, | | |

ELECTRICAL PARTS LIST

| Location | Part Number | Description |
|--|-------------|------------------------|
| R204,R227-R229,R233,R236, R260,R318,R319, R2,R8,R11,R14,R16,R26, R29,R34,R39,R45,R46,R50, R54,R57,R60,R64,R67,R74, R75,R81,R84,R87,R90,R95, R101,R102,R104,R112,R114, R116,R127,R129,R130,R140, R142,R147,R160,R162,R173, R174,R177,R193,R197,R198, R202,R203,R214,R221,R225, R226,R232,R239,R259,R271, R272,R275,R285,R293,R301, R19,R139,R304,R305,R309, R310,R314,R316 R109,R125,R143,R153, R206,R207 R69,R70 R108,R126,R154,R159, R199,R205 R306,R308,R315 R181,R182 R3,R4,R5,R7,R9,R10,R12, R13,R15,R17,R18,R20,R24, R25,R28,R30,R32,R33,R38, R40,R43,R44,R47,R48,R71-R73, R76,R78,R79,R80,R85, R86,R88,R89,R91-R94, R103,R134,R135,R141, R151,R235,R249-R251 R263,R278,R279,R284, R289,R295,R297,R298, R65,R68,R200,R234,R240, R255,R267,R273,R287,R290 R218 | 4720-104A-J | RMG 1/10W 100K 1% 0805 |
| | 4720-104J-J | RMG 1/10W 100K 5% 0805 |
| | 4720-113A-J | RMG 1/10W 11K 1% 0805 |
| | 4720-114A-J | RMG 1/10W 110K 1% 0805 |
| | 4720-133A-J | RMG 1/10W 13K 1% 0805 |
| | 4720-153J-J | RMG 1/10W 15K 5% 0805 |
| | 4720-163J-J | RMG 1/10W 16K 5% 0805 |
| | 4720-203A-J | RMG 1/10W 20K 1% 0805 |
| | 4720-224A-J | RMG 1/10W 220K 1% 0805 |
| | 4720-272J-J | RMG 1/10W 2.7K 5% 0805 |

ELECTRICAL PARTS LIST

| Location | Part Number | Description |
|--|----------------------------|--|
| R266, R270 | 4720-273A-J | RMG 1/10W 27K 1% 0805 |
| R244, R245, R246, R252, R264, R276 | 4720-333A-J | RMG 1/10W 33K 1% 0805 |
| R113, R128, R49, R53, R56, R59, R63, R66 | 4720-471A-J | RMG 1/10W 470R 1% 0805 |
| R170, R22, R23, R35, R36, R41, R42, R51, R62, R61, R52, R55, R58 | 4720-473A-J | RMG 1/10W 47K 1% 0805 |
| R133, R97 | 4720-473J-J | RMG 1/10W 47K 5% 0805 |
| R149, R224, R223, R211, R210, R192, R191, R172, R171, R150 | 4720-560A-J | RMG 1/10W 56R 1% 0805 |
| R190, R195 | 4720-822J-J | RMG 1/10W 8.2K 5% 0805 |
| R265, R256, R281, R243, R253, R254 | 4720-823A-J | RMG 1/10W 82K 1% 0805 |
| <u>DIODES</u> | | |
| D12, D15, D19, D23, D25-D34 D1-D4 | 4804-1480-3 4837-4B31-3 | DIODE LL4148 SM DZ 1/2W 4.17-4.43V |
| <u>TRANSISTOR</u> | | |
| Q7, Q9, Q10 Q1-Q6, Q8, Q11, | 485C-8070-3 485C-848C-3 | TR BC807-25 SOT23 SMD TR BC848C (1LP) HFE |
| <u>HEATSINKS</u> | | |
| IC51/52 | 5400-3421-0 | HEAT SINK |
| <u>MISCELLANEOUS</u> | | |
| L1-L7 | 1808-0680-0 | FERRITE BEAD INDUCTOR |
| IC51/52 | 2954-3008-0000 | TAPPING 3X8MM B-TITE |
| FUSE2, FUSE1, FUSE3 | 4132-1011-0 | FUSE HOLDER |

PCB ASSY POWER SWITCH **PCB BOARD**

ELECTRICAL PARTS LIST

| Location | Part Number | Description |
|--|---|--|
| <u>PCB ASSY POWER SWITCH</u> <u>PCB BOARD</u> | PCB-N0990C-PSW | PCB ASSY POWER SWITCH |
| <u>CAPACITORS</u> C761 | 8910-0049-0 | CAP400V 4700P |
| <u>SWITCH</u> | 5200-0961-0-01 | SW-PWR ALPS |
| <u>MISCELLANEOUS</u> C761 P1A | 1660-0700-0 7012-6300-0 | INSULATING BOOT (ID=14) WIRE CON ASSY L=300MM |
| <u>PCB ASSY VIDEO N0990C</u> <u>PCB BOARD</u> 3000 | PCB-N0990C-VID | PCB ASSY VIDEO N0990C |
| <u>CAPACITORS</u> C33, C34, C39-C41, C52, C54, C55, C57, C66, C67, C83, C85, C106, C141, C243, C244 C170, C174, C182, C195 C242 C38, C49, C53, C60, C63, C73 C161, C171, C186, C188, C189, C190, C196, C200, C203, C204, C210, C4, C12, C13, C21, C23-C28 C31, C35, C43, C46, C50, C56, C61, C62, C69, C70, C75, C78, C79, C101-C104, C105, C109, C110, C112, C113, C118, C120, C121, C125-C129, C131, C132, C136, C142, C143, C146, C158, C160, C165, C167, C169, C172, C173, C175, C176, C177, C179, | 150D-225K-6-CF 150F-101K-J-BD 150F-102K-J-BD 150F-103K-J-BD 150F-104K-J-BD CC 16V 2.2uF 10% 1206 CC 50V 100P 10% 0805 CC 50V 1000pF 10% 0805 1 CC 50V 0.01U 10% 0805 CC 50V 0.1uF 10% 0805 | |

ELECTRICAL PARTS LIST

| Location | Part Number | Description |
|---|--|--|
| C180, C184, C187, C191-C194, C197, C199, C201, C202, C205, C209, C212, C213, C216, C218, C221, C222, C232, C236, C139 | 150F-221K-J-BD 150F-223K-J-BD 150F-270K-J-BD 154C-225K-3-CF 154D-106M-3-EF | CC 50V 220pF 10% 0805 1. CC 50V 0.022U 10% 0805 CC 50V 27P 10% 0805 CT 10V 2.2UF 10% SM CT 16V 10uF 20% SM |
| C134 | 154D-226M-3-FK 154E-106M-3-FK 157C-107M-3-LJ | CT 16V 22UF 20% SM CT 25V 10uF 20% 3.2x6 SM CE 10V 100uF 20% SM |
| C214, C219 | | |
| C149 | | |
| C123, C166, C181, C198, C206, C207, C223 | | |
| C225 | | |
| C215, C217, C220, C224 | | |
| C1-C3, C5-C11, C14-C18, C32, C42, C44, C45, C47, C48, C51, C58, C59, C64, C68, C71, C72, C81, C82, C84, C87-C89, C90, C93, C94, C107, C119, C124, C130, C133, C135, C137, C147, C150, C151, C153, C157, C159, C178, C208, C211, C22, C241, C138, C148, C155, C162, C183 | | |
| C164 | 157C-477M-5-OU 15CG-220J-J-BD 15CG-330J-J-BD 15CH-3R9D-J-BD 15CH-8R2D-J-BD | CE 10V 470UF 20% RL 8X11 CTC 0/30 22pF 5% 0805 CTC 0/30 33pF 5% 0805 CTC 0/60 3.9pF 0.5pF CTC 0/60 8.2pF 0.5pF |
| C156, C168 | | |
| C152, C154, C231 | | |
| C185, C227 | | |
| <u>COILS</u> | | |
| TR1, TR2, TR3, TR4, TR5 | 1806-2430-0 | DIGITAL COIL 980986540 |
| <u>WAFERS/JACKS</u> | | |
| X14, X16 | 2101-0831-0 | WAFER 10PIN P2.54 DUAL |
| X11, X15 | 2101-1368-0 | REDEPTACLE 8PIN DUAL |
| X3 | 2113-1121-0 | 2P RCA JACK Y/Y AU |
| X4, X6, X8 | 2113-1744-0 | DIN JACK MIN 2P |
| X17 | 2113-1749-0 | DB9 FEMALE D SUB RA |

ELECTRICAL PARTS LIST

| Location | Part Number | Description |
|--|-------------|--------------------------|
| X1,X2 | 2113-1752-0 | RCA JACK 4P Y.Y. GOLD |
| X9 | 2113-1753-0 | RCA JACK 4P G.B. GOLD |
| X12 | 2113-1754-0 | RCA JACK 4P BL.BL. GOLD |
| X10 | 2113-1755-0 | RCA JACK 4P R.O. GOLD |
| X7,X5 | 2113-1758-0 | SVHS JACK |
| <u>CRYSTAL</u> | | |
| CR4 | 2300-1240-0 | CRYSTAL 12MHZ |
| CR3 | 2300-1980-0 | CRYSTAL OSCILLATOR EPSON |
| CR2 | 2300-2000-0 | CRYSTAL 17.734475 MHZ |
| CR1 | 2300-3020-0 | X'TAL 14.318MHZ +-20PPM |
| <u>IC</u> | | |
| IC1-IC3,IC7,IC8,IC10, IC12,IC21,IC22,IC25 | 3130-1730-0 | IC HCF4066BM1 |
| IC26 | 3130-4990-0 | IC LM393D DUAL VOLTAGE |
| IC35 | 3130-6410-0 | IC Z86E08 OTP |
| IC33 | 3130-6590-0 | IC 74HC74 DUAL D-TYPE |
| VR1 | 3130-7010-0 | IC LM431ACZ ADJ REG |
| IC24 | 3131-3520-0 | IC STV5730A OSD |
| IC30 | 3131-7280-0 | IC 74HC244 10x13 SOP20 |
| IC4,-IC6,IC11,IC14-IC18, IC20,IC23, | 3131-7330-0 | IC OPA2652 DUAL OP-AMP |
| IC28 | 3131-7350-0 | IC AM26LS32 SOP16 SMD |
| IC37 | 3131-7360-0 | IC MAX4599EXT-T ANALOG |
| IC27 | 3131-7370-0 | IC 74AC04 HEX INVERTERS |
| IC31 | 3131-7380-0 | IC 74AC251 8-INPUT |
| IC29 | 3131-9200-0 | IC XC9536PC44 PLCC-44 |
| IC36 | 3131-9470-0 | IC MAX232D SO16 |
| IC9,IC13,IC19, IC32 | 3131-9500-0 | IC 74HC595AF 8BIT SHIFT |
| | 3131-9520-0 | IC 74HC165AF SHIFT |
| <u>RESISTOR</u> | | |
| R230,R214,R208,R205,R78, R73,R3,R294,R290,R289, | 4720-000J-J | RMG 1/10W 0R 5% 0805 |

ELECTRICAL PARTS LIST

| Location | Part Number | Description |
|--|---|---|
| R288, R252, R245, R234, R233, R231 | 4720-100J-J 4720-101J-J 4720-102A-J | RMG 1/10W 10R 5% 0805 RMG 1/10W 100R 5% 0805 RMG 1/10W 1K 1% 0805 |
| R273 R199, R201, R202 R21, R26, R28, R44, R46, R47, R53, R88, R110, R111, R115, R121, R122, R131, R132, R136, R141, R142, R145, R148, R151, R152, R156, R161, R170, R171, R179, R184, R191, R192, R200, R18, R42, R98, R107, R108, R168, R207, R296 | 4720-103A-J 4720-103J-J | RMG 1/10W 10K 1% 0805 RMG 1/10W 10K 5% 0805 |
| R64, R66, R67, R69, R72, R76, R79, R81, R93, R94, R97, R101, R102, R103, R105, R127, R129, R134, R138, R144, R149, R154, R157, R223, R229, R235, R236, R238, R239, R241, R242, R249, R284, R43, R114, R135, R160, R183, R193 | 4720-104A-J 4720-104J-J | RMG 1/10W 100K 1% 0805 RMG 1/10W 100K 5% 0805 |
| R19, R29, R48, R54, R165, R185, R195, R197, R203, R204, R212, R217, R219, R220, R222, R247, R253, R172 R95, R109, R264, R268, R282, R291, R293, R276 R281 R182 R206, R209 R221 R164 R240, R243 | 4720-151J-J 4720-220J-J 4720-221A-J 4720-222A-J 4720-223A-J 4720-242A-J 4720-271A-J 4720-273A-J 4720-331J-J | RMG 1/10W 150R 5% 0805 RMG 1/10W 22R 5% 0805 RGM 1/10W 220R 1% 0805 RMG 1/10W 2.2K 1% 0805 RMG 1/10W 22K 1% 0805 RMG 1/10W 2.4K 1% 0805 RMG 1/10W 270R 1% 0805 RMG 1/10W 27K 1% 0805 RMG 1/10W 330R 5% 0805 |

ELECTRICAL PARTS LIST

| Location | Part Number | Description |
|--|-------------|--------------------------|
| R278 | 4720-332A-J | RMG 1/10W 3.3K 1% 0805 |
| R211 | 4720-392A-J | RMG 1/10W 3.9K 1% 0805 |
| R244 | 4720-432J-J | RMG 1/10W 4.3K 5% 0805 |
| R213,R216,R232,R237 | 4720-471A-J | RMG 1/10W 470R 1% 0805 |
| R86,R87 | 4720-472A-J | RMG 1/10W 4.7K 1% 0805 |
| R210,R246 | 4720-472J-J | RMG 1/10W 4.7K 5% 0805 |
| R11,R20,R23,R25,R50,R113 | 4720-473A-J | RMG 1/10W 47K 1% 0805 |
| R120,R130,R140,R147, R150,R169, R2,R6,R8,R9,R12,R15-R17, R31,R32,R35,R38-R40,R49, R52,R55,R60,R62,R74,R80, R90,R99,R139,R146,R155, R162,R175,R176,R180, R181,R189,R190,R287, R295,R297,R298,R300 | 4720-474J-J | RMG 1/10W 470K 5% 0805 |
| R274 | 4720-560J-J | RMG 1/10W 56R 5% 0805 |
| R173,R177,R178 | 4720-561J-J | RMG 1/10W 560R 5% 0805 |
| R1,R5,R7,R10,R13,R14,R22, R24,R30,R51,R57,R59,R61, R63,R68,R71,R75,R77,R83, R84,R91,R92,R100,R104, R106,R112,R116,R126,R143, R153,R163,R167,R186,R187, R194,R196,R218, R250,R251 | 4720-562A-J | RMG 1/10W 5.6K 1% 0805 |
| L1-L21,L23-L25 D56 | 4720-750A-J | RMG 1/10W 75R 1% 0805 |
| | 4720-750J-J | RMG 1/10W 75R 5% 0805 |
| | 4721-000J-6 | RMG 1/8W OR 5% 1206 |
| | 4721-474J-6 | RMG 1/8W 470K 5% 1206 |
| <u>DIODES</u> | 4804-1480-3 | DIODE LL4148 SM |
| D2,D4,D6,D8,D10,D12-D17,D19, D20,D23,D24,D27,D28,D31,D32, D34,D36,D37,D40,D41,D43,D44, D46,D47,D49,D51-D55,D57 D1,D3,D5,D7,D9,D11,D18, | 4840-1990-3 | DIODE BAS70-04 DOUBLE SC |

ELECTRICAL PARTS LIST

| Location | Part Number | Description |
|--|--------------------|-----------------------|
| D21, D22, D25, D26, D29, D30, D33, D35, D39, D38, D42, D45, D48, D50, | | |
| <u>MISCELLANEOUS</u> | | |
| L26-L29 | 1808-0680-0 | FERRITE BEAD INDUCTOR |
| CR1, CR2, CR4 | 3100-5121-0 | INSULATION WASHER, |
| RCVR1, RCVR2 | 4811-F32R-3 | LIGHT RX UNIT GPIF32R |
| TRNSM1 | 4811-F32T-3 | LIGHT TX UNIT GP1F32T |

EXPLODED VIEW

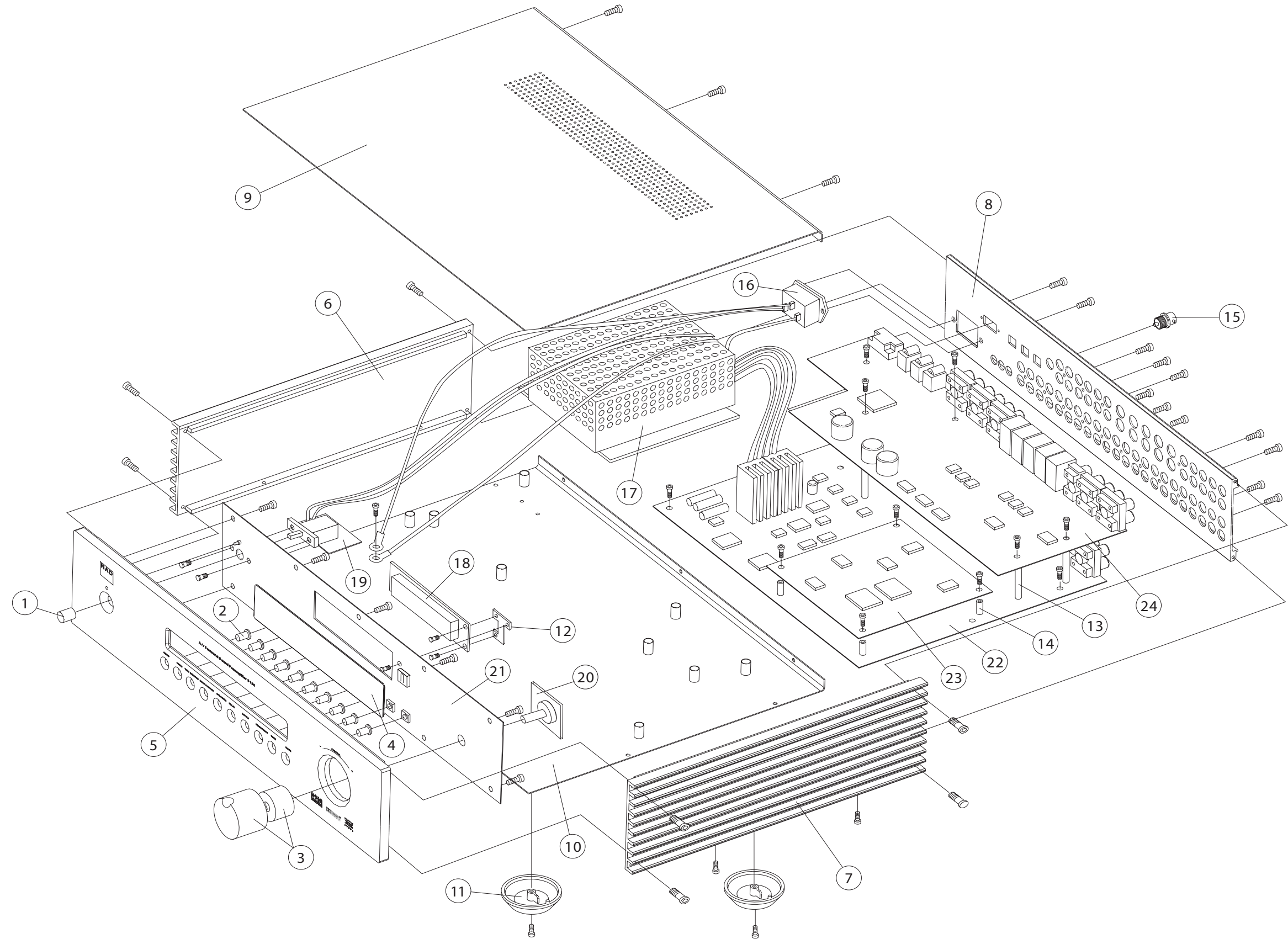

EXPLODED VIEW

| LOCATION | PART NUMBER | DESCRIPTION |
|----------|------------------|---|
| 1 | S100-2011-3 | Power button 10mm |
| 2 | S100/S300-2121-1 | Input button |
| 3 | S170-2032-1 | Volume Knob Assembly (two parts, inner and outer-shell) |
| 4 | S170-2052-1 | Display Lens |
| 5 | S170-2002-4 | Aluminum Fascia |
| 6 | S170-2014-4 | Left Side Panel |
| 7 | S170-2024-2 | Right Side Panel |
| 8 | S170-2002-4 | Rear Panel |
| 9 | S170-2004-1 | Top Cover |
| 10 | S170-2034-4 | Base Cover |
| 11 | S100-2013-2 | Foot |
| 12 | GPE-PCB KIT | Bracket (NSP) Part of GPE-PCB KIT |
| 13 | S170-2234-2 | Stand-Off A (longer stand-off) |
| 14 | S170-2334-3 | Stand-OFF B (shorter stand-off) |
| 15 | GPE-PCB KIT | BNC chassis-mount for Digital Input (NSP) Part of GPE-PCB KIT |
| 16 | T40C | IEC female plug (NSP) Part of the Power Supply |
| 17 | T40C | Power Supply |
| 18 | GPE-PCB KIT | Florescent Display (NSP) Part of GPE-PCB KIT |
| 19 | GPE-PCB KIT | Power Switch and PCB with cables (NSP) Part of GPE-PCB KIT |
| 20 | GPE-PCB KIT | Volume Control Module (NSP) Part of GPE-PCB KIT |
| 21 | GPE-PCB KIT | Front Panel PCB with Power Switch & PCB with cables, and Volume Control Module (NSP) Part of GPE-PCB KIT |
| 22 | GPE-PCB KIT | Main PCB with Linear Power Supply, Audio Inputs & Outputs, and Trigger Out (NSP) Part of GPE-PCB KIT |
| 23 | Gen6 A367 | Gen6 A367 DSP Assembly (NSP) |
| 24 | GPE-PCB KIT | Secondary PCB with Video Inputs & Outputs, S-Video Outputs, Component Inputs & Outputs, Digital and TOSLINK Inputs & Outputs. (NSP) Part of GPE-PCB KIT |
| *** | GPE-PCB KIT | Three Assemblies; Main, Secondary, Front Panel PCBs, not including Gen6 A367 |

PACKING DIAGRAM

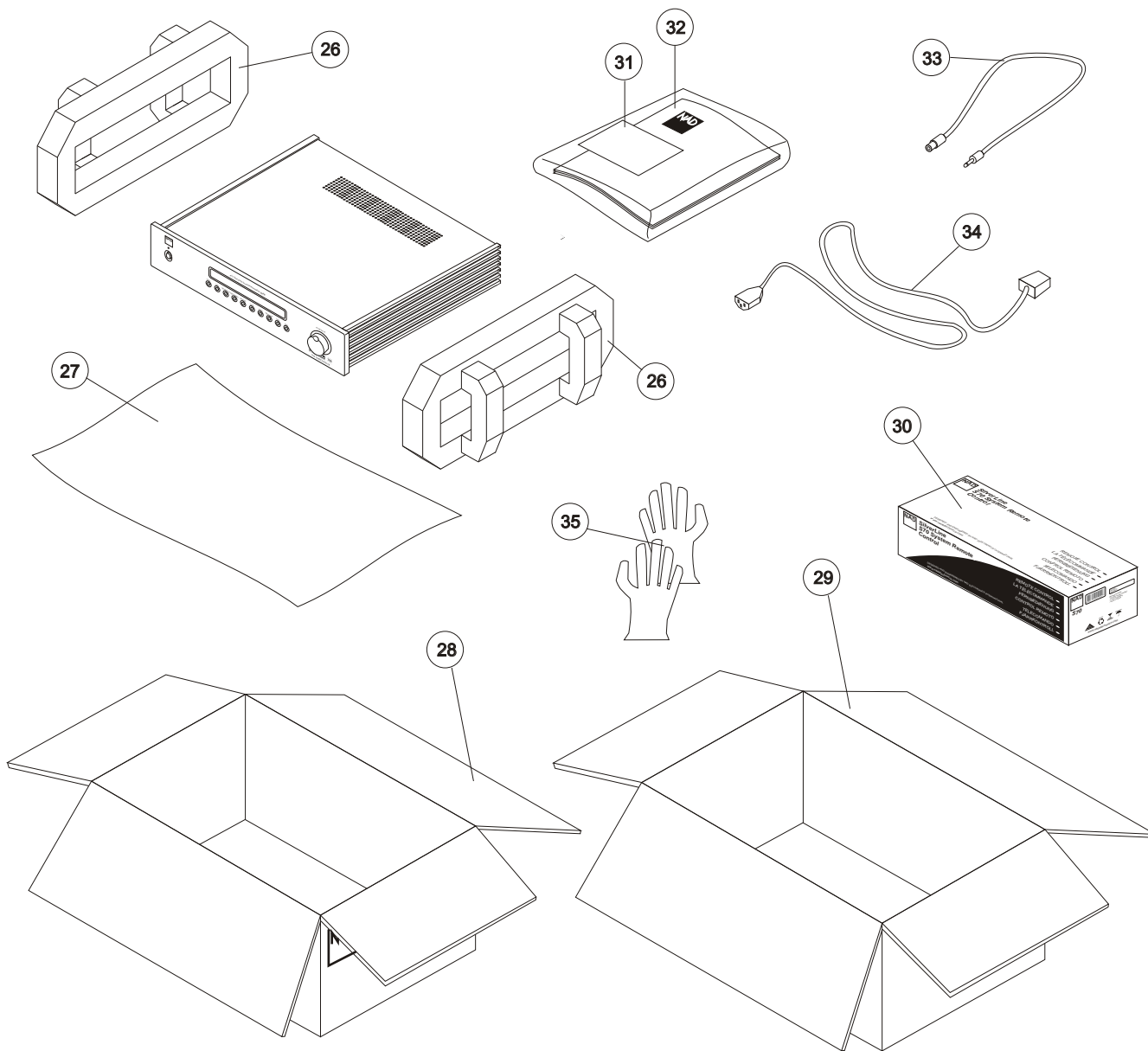

| ITEM | PART NUMBER | DESCRIPTION | QTY. |
|-------|-------------|---------------------------|--------|
| 26 | 8700.0062 | CUSHION | 2 |
| 27 | 8700.0057 | WRAPPING SHEET | 1 |
| 28 | 862004 | INNER CARTON BOX | 1 |
| 29 | 862005 | OUTER CARTON BOX | 1 |
| 30 | HTR-2 | REMOTE CONTROL W/ BATTERY | 1 SET |
| 31 | 8120.0189 | WARRANTY CARD | 1 |
| 32 | S170-IM | OWNER'S MANUAL | 1 |
| 33 | 4150.0022 | 12V TRIGGER CABLE | 1 |
| 34*AH | 4150.0025 | POWER CORD 120V | 1 |
| 34*C | 4150.0024 | POWER CORD 230V | 1 |
| 35 | 8700.0056 | GLOVES | 1 PAIR |

NOTES

Dotted lines for writing notes.

SERVICE MANUAL

Copyright 2003
NAD Electronics International
633 Granite Court
Pickering, Ontario
Canada L1W 3K1

No portion of this publication may be reproduced without the written permission of NAD Electronics International. Many of the circuits and software programs described within are covered by patents and other international property laws and are used with express permission or license agreements from the owners.

Printed in Canada

S170i
AV SURROUND
SOUND
PREAMPLIFIER